

METHOD OF THE DYNAMIC ANALYSIS OF THE MECHANISM

Valery Malkov, Alla Vlasova, Pavel Nosko, Valery Stavitsky

*Volodymyr Dahl East-Ukrainian National University, Lugansk, Ukraine;
Science research and design construction institute "ISKRA", Lugansk, Ukraine*

Summary. The iterative method of the law of movement of an initial link of the lever mechanism in time of settled regime definition, not connected with dynamic synthesis, is offered.

Key words: lever mechanism, link of reduction, settled regime, dynamic analysis, law of movement

INTRODUCTION

As it is known from the educational literature (see the list of referred sources), for the decision of a problem of the dynamic analysis of the mechanism, it is necessary to know parameters of its dynamic model (the angular speed, the resulted moment of inertia, change of kinetic energy) at least in one position defined in the generalized coordinate. Traditional methods [Korenyako 1970] suggest to use as such position, where angular speed of a link of reduction has extreme value set by the coefficient of non-uniformity of movement. But maintenance of the set coefficient of non-uniformity of movement is a condition of dynamic synthesis of the mechanism, which is not always necessary. Thus, it appears that without dynamic synthesis, when this factor is not known also it only it is necessary to define, the dynamic analysis is impracticable. Possibility of definition of the law of movement of an initial link in this case opens the nonconventional approach to the decision of a problem of dynamic synthesis [Malkov 2008].

OBJECTS AND PROBLEMS

Let the resulted moment of inertia of the lever mechanism will be presented as follows:

$$J(\varphi) = J_{const} + J_{var}(\varphi),$$

where: J_{const} - the constant component allocated in such a manner, that a variable component $J_{var}(\varphi)$ has the minimum 0; φ - the generalized coordinate.

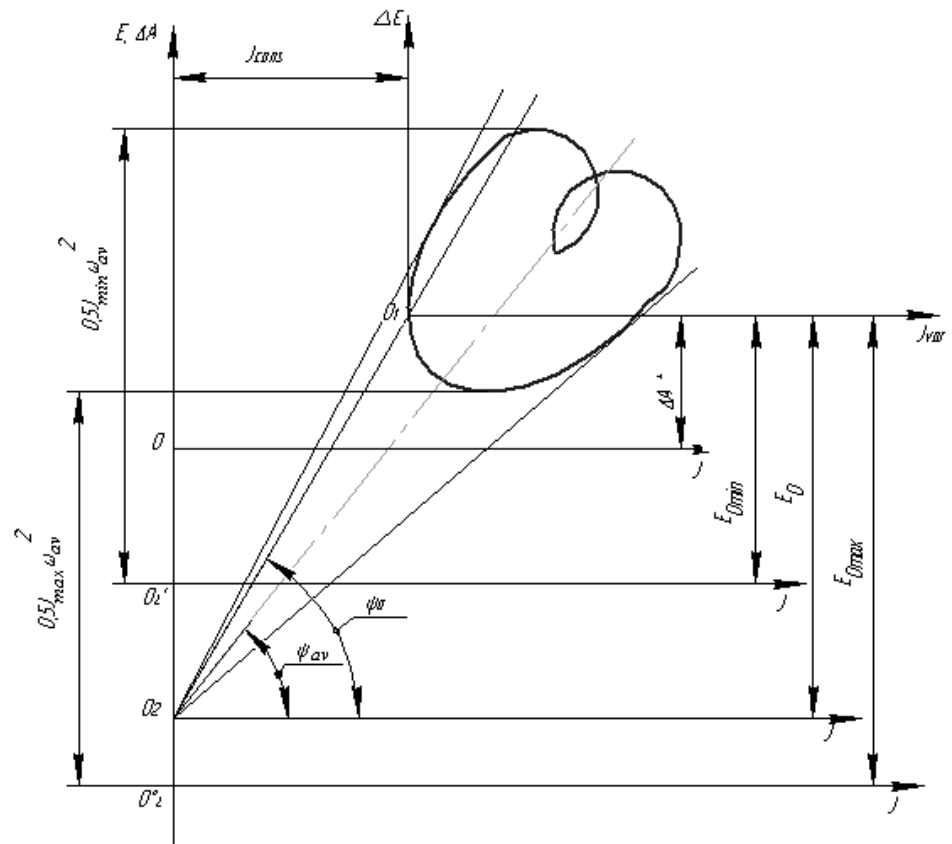

Fig. 1. To the dynamic analysis of the mechanism

In figure 1 the curve of energy-mass (Vittenbauer's diagram) received in the traditional way in system of coordinates $JO\Delta A$, expressing conformity of values of total work $\Delta A(\varphi)$ to values of the resulted moment of inertia of the mechanism $J(\varphi)$ is represented. After an exception of a constant component of the resulted moment of inertia J_{const} , having passed to new system of coordinates $J_{var}O_1\Delta E$, it is possible to write down:

$$J_{var}(\varphi) = J(\varphi) - J_{const}$$

and

$$\Delta E(\varphi) = \Delta A(\varphi) - \Delta A^*,$$

where: J_{const} - the minimum value of the resulted moment of inertia in old system $JO\Delta A$, ΔA^* - ordinate corresponding to this value in the same system, $\Delta E(\varphi)$ - a

variable component of change of kinetic energy of the mechanism in new system of coordinates $J_{\text{var}} O_1 \Delta E$.

Point O_2 of crossing of tangents to a curve of the energy-mass, defining unknown the maximum ω_{max} and minimum ω_{min} values $\omega(\varphi)$, is the beginning of system of coordinates $JO_2 E$, in which the curve of energy-mass describes dependence of full kinetic energy of the mechanism from the resulted moment of inertia $E = E(J)$. It is possible to present this dependence as follows:

$$E = E_0 + \Delta E(\varphi) = \frac{(J_{\text{const}} + J_{\text{var}}(\varphi)) \cdot \omega^2(\varphi)}{2}. \quad (1)$$

Here $E_0 = \frac{J_{\text{const}} \cdot \omega_0^2}{2}$ - an unknown constant component of kinetic energy,

where ω_0 - some unknown angular speed at $J_{\text{var}}(\varphi) = 0$ and $\Delta E(\varphi) = 0$. To this speed on fig. 1 there corresponds straight line $O_2 O_1$, inclined at an angle ψ_0 to an axis of abscisses.

Thus, having E_0 , from expression (1) it is possible to define current values of angular speed:

$$\omega(\varphi) = \sqrt{\frac{2 \cdot (E_0 + \Delta E(\varphi))}{J_{\text{const}} + J_{\text{var}}(\varphi)}} = \sqrt{\frac{2 \cdot (E_0 + \Delta E(\varphi))}{J(\varphi)}} \quad (2)$$

The problem of the dynamic analysis can be solved an iterative way, using the received dependence (2). The method essence is easy for understanding, having addressed to figure 1. In this case the curve of energy-mass set in system of coordinates $JO\Delta A$, it is necessary to transfer in system of the coordinates $JO_2 E$, which beginning O_2 settles down on continuation of an axis of ordinates ΔA in a point of intersection from the straight line corresponding to set average angular speed ω_{av} , i.e. inclined at an angle ψ_{av} to an axis of abscisses. It is required to define position of this point. The block diagram of algorithm of the decision of a problem is represented in figure 2.

Having set by the initial data $J(\varphi)$, $\Delta A(\varphi)$, ω_{av} and an admissible relative deviation from size of average angular speed Δ_{ω} , it is necessary to pass from system $JO\Delta A$ in system $J_{\text{var}} O_1 \Delta E$, as it is described above. The least value of the resulted moment of inertia $J_{\text{min}} = J_{\text{const}}$ is thus defined. Then its greatest value J_{max} , and also the greatest ΔE_{max} and least ΔE_{min} values of function $\Delta E(\varphi)$ are also defined.

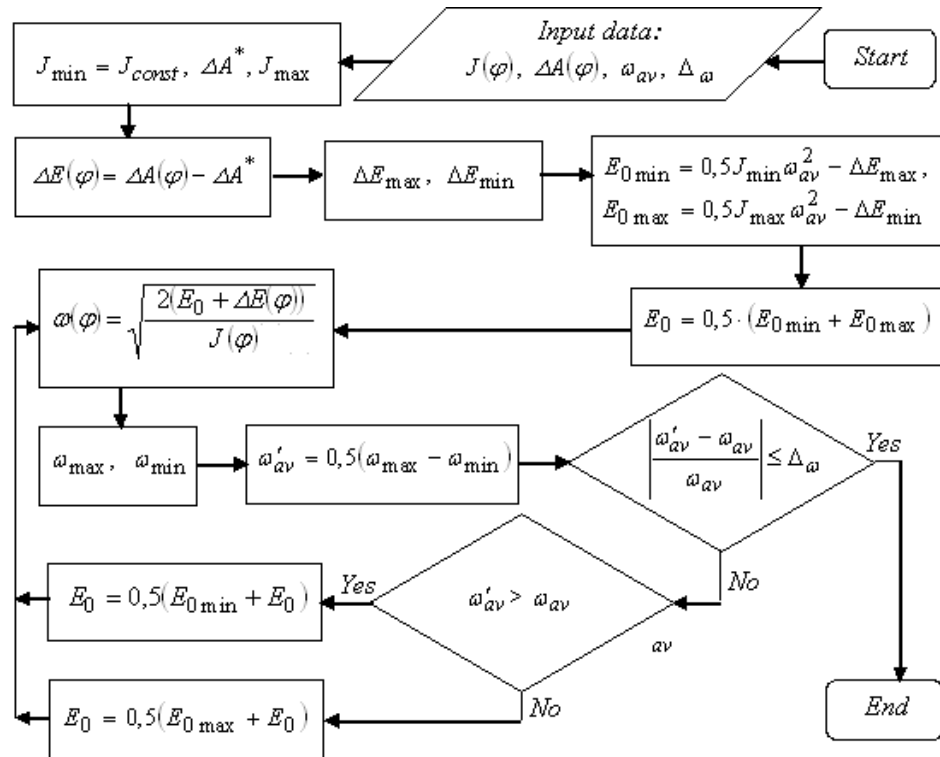

Fig. 2. The block diagram of algorithm of the dynamic analysis of the mechanism

Position of point O_2 is defined by size of kinetic energy E_0 , which it is offered to search a method consecutive approaches. It is obvious, that the point O_2 settles down on a piece $O'_2 O''_2$, which borders O'_2 and O''_2 will arrange from the top and bottom points of a curve of energy-mass on distances, that with sufficient accuracy are defined by energy sizes accordingly $0,5J_{\min}\omega_{av}^2$ and $0,5J_{\max}\omega_{av}^2$, and from an axis of abscisses of system of coordinates $J_{\text{var}}O_1 \Delta E$ in sizes

$$E_{0\min} = 0,5J_{\min}\omega_{av}^2 - \Delta E_{\max} \quad \text{and} \quad E_{0\max} = 0,5J_{\max}\omega_{av}^2 - \Delta E_{\min}.$$

At the first stage it is possible to accept, that $E_0 = 0,5 \cdot (E_{0\min} + E_{0\max})$. Then under the formula (2) angular speed of a link of reduction in all positions of the mechanism is calculated. Its extreme values and new value of average angular ω'_{av} speed are defined. The last is compared to the set ω_{av} . If the absolute relative size of their difference exceeds the set admission Δ_{ω} , it is necessary to find new position of the beginning O_2 of system of coordinates JO_2E , having accepted new value E_0 .

Thus in a case, when $\omega'_{av} > \omega_{av}$, the point O_2 settles down on the midpoint of piece $O_2O'_2$, differently – on the midpoint of piece $O_2O''_2$. Procedure repeats. Iterative process proceeds until the deviation of the calculated value of average angular speed of a link of reduction from a preset value will not appear within the admission.

Angular acceleration of a link of reduction can be defined traditional [Frolov 1999] or nonconventional [Malkov 2008] methods.

CONCLUSIONS

Some advantages of the stated method.

- Possibility of performance of the dynamic analysis without dynamic synthesis.
- Possibility of creation of simple algorithm for the machine account.
- Continuity in relation to traditional methods and basic ideas.
- Presentation owing to possibility of application of a simple graphic illustration.

REFERENCES

1. Artobolevsky I. I., 1988.: Theory of mechanisms and machines. Textbook for higher technical educational institutes, «Science», Moscow, 640 p.
2. Belokonev I. M., 1990.: Theory of mechanisms and machines. Methods of automatic designing. Educational appliance for higher technical educational institutes, «Higher school», Kiev, 208 p.
3. Frolov K. V., etc., 1999.: Theory of mechanisms and machines. Textbook for higher technical educational institutes, «Higher school», Moscow, 496 p.
4. Gavrilenko V. A., etc., 1973.: Theory of mechanisms. Educational appliance for higher technical educational institutes, «Higher school», Moscow, 511 p.
5. Iosilevich G. B., Lebedev P. A., Strelyaev V. S., 1985.: Applied mechanics. For students of higher technical educational institutes, «Machine-building», Moscow, 576 p.
6. Kinitsky Ya. T., 2002.: Theory of mechanisms and machines. Textbook, «Science idea», Kiev, 660 p.
7. Kogchevnikov S. N., 1973.: Theory of mechanisms and machines. Educational appliance for students of higher educational institutes, «Machine-building», Moscow, 592 p.
8. Kolchin N. I., Movnin M. S., 1962.: Theory of mechanisms and machines. Textbook for machine-building higher educational institutes, «Sudpromgiz», Leningrad, 616 p.
9. Korenyako A. S., 1976.: Theory of mechanisms and machines. Educational appliance for higher technical educational institutes, «Higher school», Kiev, 444 p.
10. Korenyako A. S., etc., 1970.: Theory of mechanisms and machines year designing. Educational appliance for higher technical educational institutes, «Higher school», Kiev, 330 p.
11. Kulbachny O. I., etc., 1970.: Theory of mechanisms and machines. Designing. Educational appliance for higher educational institutes, «Higher school», Moscow, 287 p.
12. Levitskaya O. N., Levitsky N. I., 1985.: Course of theory of mechanisms and machines. Educational appliance for higher educational institutes, «Higher school», Moscow, 279 p.
13. Levitsky N. I., 1990.: Theory of mechanisms and machines. Educational appliance for higher educational institutes, «Science», Moscow, 592 p.

14. Malkov V. N., Vlasova A. A., 2008.: An advanced method of dynamic synthesis and the dynamic analysis of the mechanism [the electronic resource] / Herald of V. Dahl East-Ukrainian National University, № 3E. An access mode to magazine: <http://www.nbu.gov.ua/e-journals/vusnud>.
15. Margolin Sh. F., 1968.: Theory of mechanisms and machines. Textbook. «Higher school», Minsk, 357 p.
16. Mashkov A. A., 1971.: Theory of mechanisms and machines. Textbook. «Higher school», Minsk, 469 p.
17. Popov S. A., 1986.: Theory of mechanisms and mechanics of machines year designing. Educational appliance for higher technical educational institutes, «Higher school», Moscow, 295 p.
18. Yudin V. A., Petrokas L. V., 1977.: Theory of mechanisms and machines. Textbook for higher technical educational institutes, «Higher school», Moscow, 622 p.
19. Zablonsky K. I., Belokonev I. M., Schekin B. M., 1989.: Theory of mechanisms and machines. Textbook, «Higher school», Kiev, 376 p.
20. Zablonsky K. I., etc., 1979.: Applied mechanics. Educational appliance for higher educational institutes, «Higher school», Kiev, 280 p.
21. Zinoviev V. A., 1972.: Course of theory of mechanisms and machines. Educational appliance for higher educational institutes, «Science», Moscow, 384 p.

МЕТОД ДИНАМИЧЕСКОГО АНАЛИЗА МЕХАНИЗМА

Валерий Мальков, Алла Власова, Павел Носко, Валерий Ставицкий

Аннотация. Предлагается итерационный метод динамического анализа, позволяющий определить закон движения звена приведения механизма при установившемся режиме независимо от динамического синтеза.

Ключевые слова: рычажный механизм, звено приведения, установившейся режим, динамический анализ, закон движения.