

# ANALYTICAL EVALUATION OF THE UNCERTAINTY OF COORDINATE MEASUREMENTS OF GEOMETRICAL DEVIATIONS. MODELS BASED ON THE DISTANCE BETWEEN POINT AND PLANE

Władysław Jakubiec, Wojciech Płowucha

## Summary

In this paper a series discussing the possibility of analytical evaluation of the uncertainty of coordinate measurements is presented. It presents models of evaluation of uncertainty of some geometric deviations (such as flatness, perpendicularity of axes, position of point, axis and plane) based on the formula for the point-plane distance. An important element of the presented methodology for determining the uncertainty of measurement is the use of mathematical minimum number of characteristic points of the measured workpiece and expressing the deviation as a function of coordinates' differences of the points.

**Keywords:** coordinate measuring technique, measurement uncertainty, geometrical deviations

## Analityczne wyznaczanie niepewności współrzędnościowych pomiarów odchyłek geometrycznych. Modele bazujące na odległości punktu od płaszczyzny

### Streszczenie

W artykule omówiono możliwość analitycznego określania niepewności pomiarów współrzędnościowych. Przedstawiono modele wyznaczania niepewności niektórych odchyłek geometrycznych (np. płaskości, prostopadłości osi, pozycji) bazujące na równaniach na odległość punktu od płaszczyzny. Istotnym elementem tej metodyki wyznaczania niepewności pomiaru jest przyjęcie minimalnej liczby charakterystycznych punktów mierzonego przedmiotu oraz wyrażenie odchyłki jako funkcji różnic wartości współrzędnych tych punktów.

**Słowa kluczowe:** współrzędnościowa technika pomiarowa, niepewność pomiaru, odchyłki geometryczne

## 1. Introduction

The previous paper [1] presented the theoretical background of the analytical evaluation of uncertainty of coordinate measurements and the models based on the formula for the distance between a point and a line. In particular, it described the models to assess the uncertainty of measurement of geometric

---

Address: Władysław JAKUBIEC, DSc Eng., Wojciech PŁOWUCHA, PhD Eng., University of Bielsko-Biała, Laboratory of Metrology, 43-309 Bielsko-Biała, Willowia 2, Poland, phone: +48 33 8279 321, fax: +48 33 8279 300, e-mail: wjakubiec@ath.eu

deviations such as straightness, concentricity, parallelism of the axis (cylindrical tolerance zone) and the perpendicularity of axis in regard to the plane.

This article presents models based on the formula for the distance between a point and a plane. In particular, the models to assess the uncertainty of measurement of geometric tolerances such as: flatness, parallelism of axes in the plane normal to common plane, position of a point, axis and plane in regard to datum plane, perpendicularity of axes in space, perpendicularity of a plane to the datum axis, total axial run-out, parallelism of axes in the common plane, parallelism of axis in regard to datum plane, parallelism of planes, parallelism of a plane to datum axis, parallelism of planes and perpendicularity of planes.

## 2. General model of measuring the distance between point and plane

In the coordinate measuring technique the distance  $l$  of point  $S$  from the plane  $p$  given by any point  $P$  belonging to this plane and the unit normal vector  $u$  is calculated as follows:

$$l(S, p) = |(P - S) \cdot u| \quad (1)$$

Particular tasks described below differ in the minimum number of points required for their determination and a way to define the vector  $u$ .

It should be noted that in all models the deviation is a function of the difference of coordinates of points used to determine the deviation. In all the formulae a simplified notation of the difference of coordinates of two points is used – for example:  $x_{BA} = x_B - x_A$ .

## 3. Measurement models of the flatness, the parallelism of axes in the plane normal to the common plane and the position of the point in regard to the primary datum plane

**The flatness** can be determined as the distance  $l$  between the point  $S$  and the plane defined by three points  $A$ ,  $B$  and  $C$  of this plane (Fig. 1). This model refers to the simplified classical method of flatness measurement. The minimum number of points required to determine the deviation is 4. Point  $S$  is nominally in the plane containing the points  $A$ ,  $B$  and  $C$ .

**The parallelism of axes** in the plane normal to the common plane can be determined by the distance  $l$  between the point  $S$  of the tolerated axis and the plane defined by the two points ( $A$  and  $B$ ) of the datum axis and one point ( $C$ ) of the tolerated axis. The minimum number of points required to determine the

deviation is 4 (Fig. 2). In this case, the point  $S$  nominally lies in the plane containing the points  $A$ ,  $B$  and  $C$ .

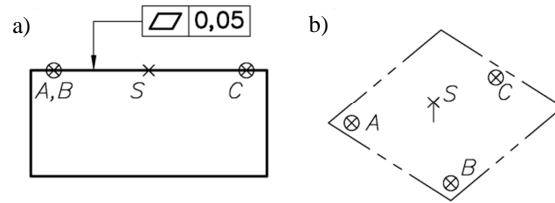

Fig. 1. Measurement of flatness: a) a design drawing with characteristic points, b) measurement model

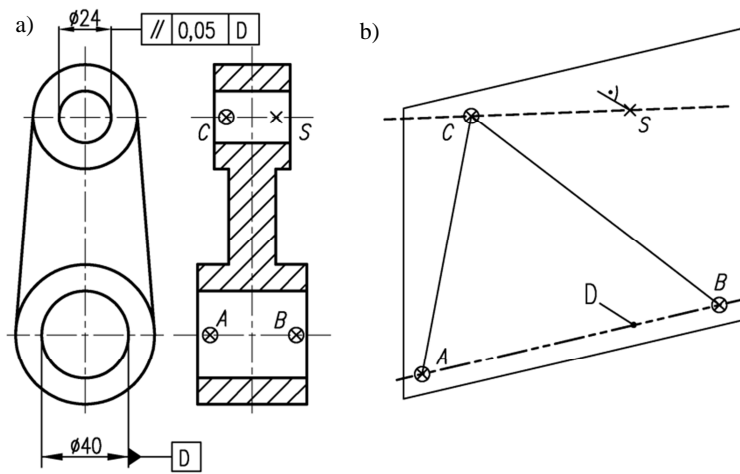

Fig. 2. Measurement of parallelism of axes in the plane normal to the common plane: a) a design drawing with characteristic points, b) measurement model

In the above tasks, plane  $p$  (from the formula (2)) is given by the three points  $A$ ,  $B$  and  $C$ . As the point  $P$  to the formula (1) you can adopt one of these points ( $A$ ,  $B$  or  $C$ ) and the normal unit vector  $u$  can be calculated according to the formula:

$$u = \frac{AB \times AC}{|AB \times AC|} \quad (2)$$

Depending on whichever point we assume as the point  $P$ , we get the following three models:

$$l_1 = \left| \frac{ax_{SA} + by_{SA} + cz_{SA}}{m} \right| \quad (3)$$

$$l_2 = \left| \frac{ax_{SB} + by_{SB} + cz_{SB}}{m} \right| \quad (4)$$

$$l_3 = \left| \frac{ax_{SC} + by_{SC} + cz_{SC}}{m} \right| \quad (5)$$

where:

$$\left. \begin{aligned} a &= y_{BA}z_{CA} - z_{BA}y_{CA} \\ b &= x_{CA}z_{BA} - x_{BA}z_{CA} \\ c &= x_{BA}y_{CA} - x_{CA}y_{BA} \\ m &= \sqrt{a^2 + b^2 + c^2} \end{aligned} \right\} \quad (6)$$

As the uncertainty of measurement the smallest of the three combined uncertainties calculated on the basis of the above formulae is assumed:

$$u = \min\{u_{l_1}, u_{l_2}, u_{l_3}\} \quad (7)$$

**The position of the point, axis or plane in regard to the datum plane** defined by three points (Fig. 3-5) can be determined as the doubled difference between the distance  $l$  of this point from the plane and the theoretically exact distance  $l_{TED}$ .

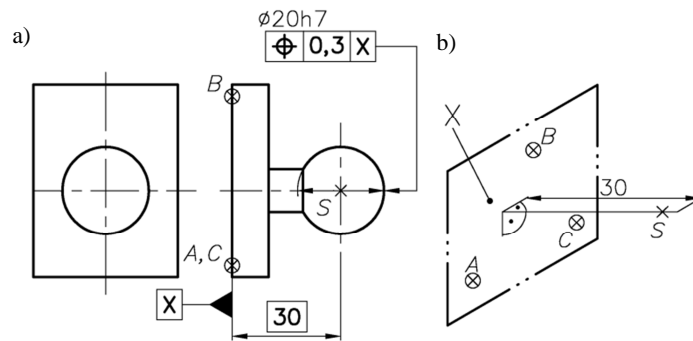

Fig. 3. Measurement of position of the point in regard to the datum plane:  
a) a design drawing with characteristic points, b) measurement model

$$\Delta = 2 \cdot |l - l_{TED}| \quad (8)$$

It can be proved that the uncertainty of the determination of the position deviation is two times bigger than the uncertainty of measurement of the distance of the characteristic point  $S$  from the datum plane  $ABC$ .

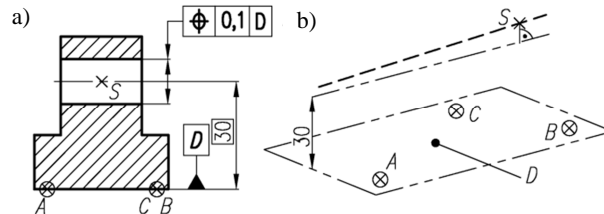

Fig. 4. Measurement of position of the axis in regard to the datum plane: a) a design drawing with characteristic points, b) measurement model

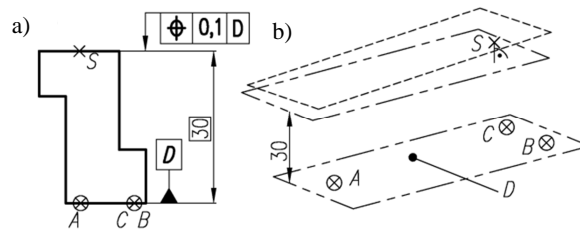

Fig. 5. Measurement of position of the plane in regard to the datum plane: a) a design drawing with characteristic points, b) measurement model

#### 4. Measurement model of perpendicularity of axes, perpendicularity of plane in regard to axis and total axial run-out

**The perpendicularity of axes in space** can be calculated as the distance  $l$  of the point  $S$  from the plane perpendicular to the straight line  $AB$  and containing the point  $K$  (Fig. 6). The minimum number of points required to determine the deviation is 4. The datum axis is represented by 2 points  $A$  and  $B$ . The axis the orientation of which is tolerated is represented by the points  $K$  and  $S$ .

**The perpendicularity of a plane in regard to a datum axis** as well as **total axial run-out** (Fig. 7) can be calculated in the same way as the perpendicularity of axes in space. The minimum number of points required to determine the deviation is 4. The datum axis is represented by 2 points  $A$  and  $B$ . The plane the orientation (or the run-out) of which is tolerated is represented by the points  $K$  and  $S$ .

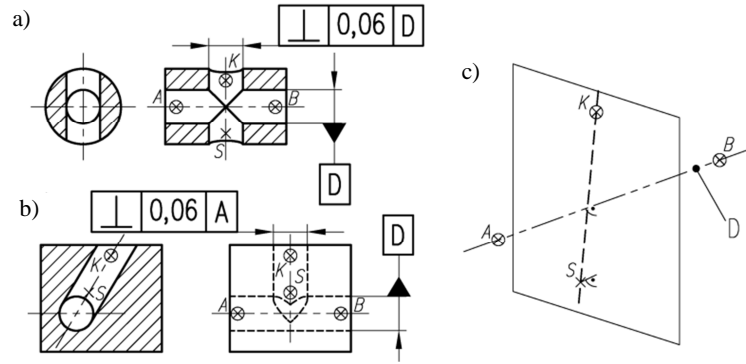

Fig. 6. Measurement of perpendicularity of axes in space:  
 a), b) design drawings with characteristic points, c) measurement model

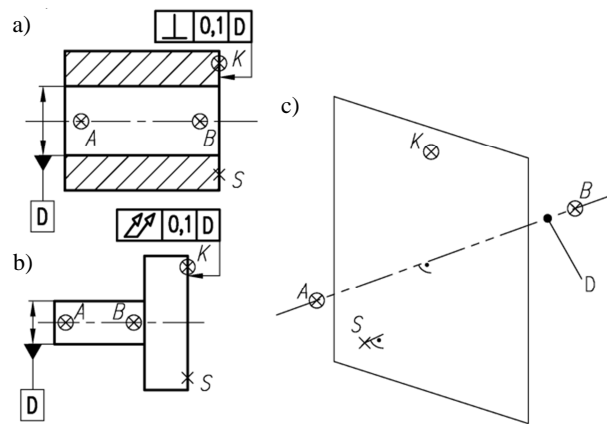

Fig. 7. Measurement of perpendicularity of plane in regard to axis  
 and the measurement of total axial run-out: a), b) corresponding  
 design drawings with characteristic points, c) measurement model

In the above described measuring tasks, the plane  $p$  from the formula (1) is perpendicular to the straight line  $AB$  and contains the point  $K$ . As the point  $P$  in the formula (1) the point  $K$  is to be assumed and the normal unit vector  $u$  can be calculated as:

$$u = \frac{AB}{|AB|} \tag{9}$$

Finally, the formula takes the form:

$$l = \frac{|x_{KS} \cdot x_{BA} + y_{KS} \cdot y_{BA} + z_{KS} \cdot z_{BA}|}{\sqrt{x_{BA}^2 + y_{BA}^2 + z_{BA}^2}} \quad (10)$$

### 5. Measurement model for parallelism of axes in the common plane

The **parallelism of axes in the common plane** is calculated as the distance  $l$  of the point  $S$  from the plane parallel to the straight line  $AB$ , perpendicular to the plane  $ABK$  and containing the point  $K$  (Fig. 8). The minimum number of points required to determine the deviation is 4. The datum axis is represented by two points  $A$  and  $B$ . The axis the orientation of which is tolerated is represented by the points  $K$  and  $S$ .

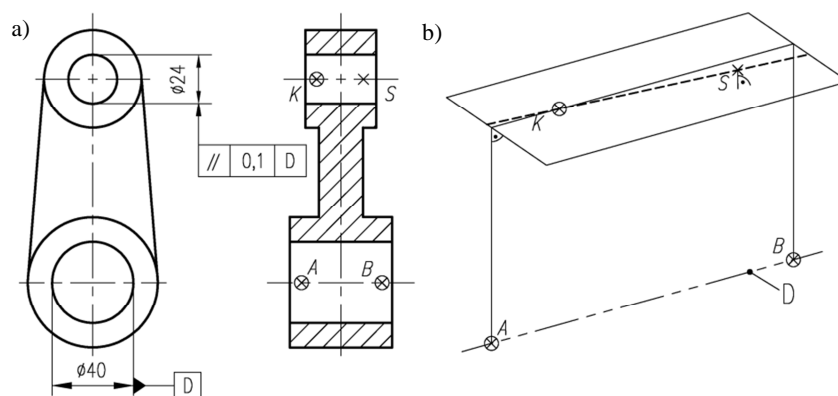

Fig. 8. Measurement of parallelism of axes in the common plane:  
a) a design drawing with characteristic points, b) measurement model

In this measuring task, the plane  $p$  from the formula (1) is perpendicular to the plane  $ABK$ , parallel to the straight line  $AB$  and contains point  $K$ . As the point  $P$  in the formula (1) the point  $K$  is to be assumed and the normal unit vector  $u$  can be calculated as the vector product of the normal vector of the plane  $ABK$  and the vector  $AB$  divided by its length:

$$u = \frac{(AB \times AK) \times AB}{|(AB \times AK) \times AB|} \quad (11)$$

Finally, the formula for calculating the parallelism of axes in the common plane is:

$$l = \frac{\sqrt{(ax_{SK})^2 + (by_{SK})^2 + (cz_{SK})^2}}{m} \quad (12)$$

where:

$$\left. \begin{aligned} a &= y_{BA}(x_{BA}y_{KA} - y_{BA}x_{KA}) - z_{BA}(z_{BA}x_{KA} - x_{BA}z_{KA}) \\ b &= z_{BA}(y_{BA}z_{KA} - z_{BA}y_{KA}) - x_{BA}(x_{BA}y_{KA} - y_{BA}x_{KA}) \\ c &= x_{BA}(z_{BA}x_{KA} - x_{BA}z_{KA}) - y_{BA}(y_{BA}z_{KA} - z_{BA}y_{KA}) \\ m &= \sqrt{a^2 + b^2 + c^2} \end{aligned} \right\} \quad (13)$$

## 6. Measurement model for parallelism of axis in regard to plane and for parallelism of planes

**The parallelism of axis in regard to plane** can be determined as the distance  $l$  between the point  $S$  and the plane parallel to the plane  $ABC$  and intersecting the point  $K$  (Fig. 9). The minimum number of points required to determine the deviation is 5. The datum plane is represented by the three points  $A$ ,  $B$  and  $C$ . The axis the orientation of which is tolerated is represented by the points  $K$  and  $S$ .

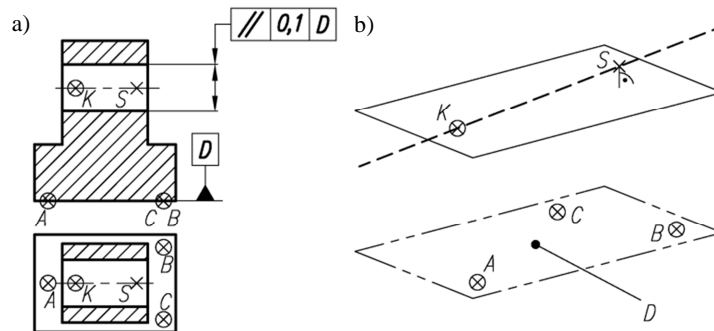

Fig. 9. Measurement of parallelism of axis in regard to plane:  
a) a design drawing with characteristic points, b) measurement model

**The parallelism of planes** can be determined as the distance  $l$  between the point  $S$  and the plane parallel to the plane  $ABC$  and intersecting the point  $K$  (Fig. 10). The minimum number of points required to determine the deviation is 5. The datum plane is represented by the three points  $A$ ,  $B$  and  $C$ . The plane the orientation of which is tolerated is represented by the points  $K$  and  $S$ .



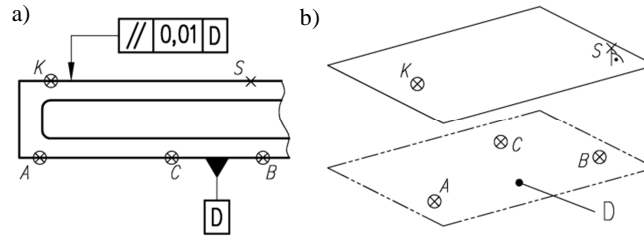

Fig. 10. Measurement of parallelism of planes: a) a design drawing with characteristic points, b) measurement model

In both measuring tasks, the plane  $p$  from the formula (1) is given by the point  $K$  and the normal unit vector  $u$  calculated as:

$$u = \frac{AB \times AC}{|AB \times AC|} \quad (14)$$

The distance between the point  $S$  and the plane is calculated as:

$$l = \frac{|ax_{KS} + by_{KS} + cz_{KS}|}{m} \quad (15)$$

where:

$$\left. \begin{aligned} a &= y_{AB} \cdot z_{AC} - z_{AB} \cdot y_{AC} \\ b &= z_{AB} \cdot x_{AC} - x_{AB} \cdot z_{AC} \\ c &= x_{AB} \cdot y_{AC} - y_{AB} \cdot x_{AC} \\ m &= \sqrt{a^2 + b^2 + c^2} \end{aligned} \right\} \quad (16)$$

## 7. Measurement model for parallelism of plane in regard to axis

The **parallelism of plane in regard to axis** can be determined as the distance  $l$  between the point  $S$  and the plane parallel to the axis  $AB$  intersecting points  $K$  and  $L$  (Fig. 11). The minimum number of points required to determine the deviation is 5. The datum axis is represented by the two points  $A$  and  $B$ . The plane orientation of which is tolerated is represented by the points  $K$ ,  $L$  and  $S$ .

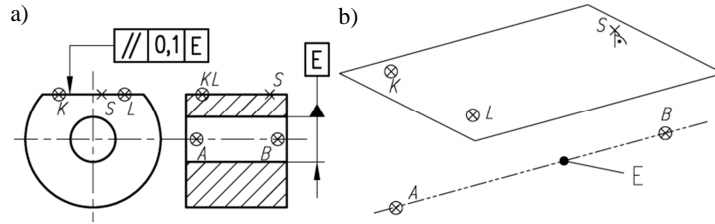

Fig. 11. Measurement of parallelism of the plane in regard to axis:  
 a) a design drawing with characteristic points, b) measurement model

In the task, the plane  $p$  from the formula (1) is parallel to both the straight line  $AB$  and the straight line  $KL$ . The normal unit vector  $u$  of that plane:

$$u = \frac{KL \times AB}{|KL \times AB|} \quad (17)$$

Finally, we can assume the following formulae for determining the perpendicularity of axis in regard to the plane:

$$l_1 = \frac{|ax_{KS} + by_{KS} + cz_{KS}|}{m} \quad (18)$$

$$l_2 = \frac{|ax_{LS} + by_{LS} + cz_{LS}|}{m} \quad (19)$$

where:

$$\left. \begin{aligned} a &= y_{BA}z_{LK} - z_{BA}y_{LK} \\ b &= z_{BA}x_{LK} - x_{BA}z_{LK} \\ c &= x_{BA}y_{LK} - y_{BA}x_{LK} \\ m &= \sqrt{a^2 + b^2 + c^2} \end{aligned} \right\} \quad (20)$$

As the uncertainty of measurement of parallelism the smaller value of the two values calculated on the basis of the above formulae is assumed.

## 8. Measurement model for perpendicularity of planes

The perpendicularity of two planes can be determined as the distance  $l$  between the point  $S$  and the plane perpendicular to the plane  $ABC$  and intersecting points  $K$  and  $L$  (Fig. 12). The minimum number of points required to determine the deviation is 6. The datum plane is represented by the points  $A$ ,  $B$  and  $C$ . The plane the orientation of which is tolerated is represented by the points  $K$ ,  $L$  and  $S$ .

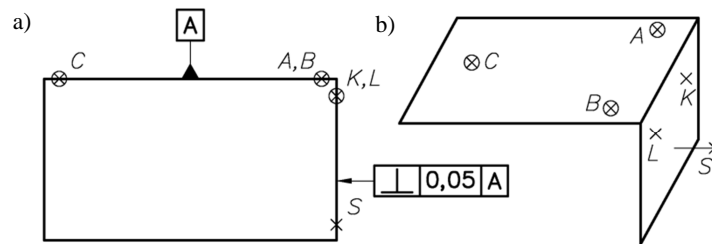

Fig. 12. Measurement of perpendicularity of the planes: a) a design drawing with characteristic points, b) measurement model

In this task, the plane  $p$  from the formula (1) is perpendicular to the plane  $ABC$  and intersects points  $K$  and  $L$ . The normal unit vector  $u$  of the plane can be calculated as:

$$u = \frac{(AB \times AC) \times KL}{|(AB \times AC) \times KL|} \quad (21)$$

As the point  $P$  in the formula (1) the point  $K$  or the point  $L$  can be assumed.

## 9. Summary

The accuracy evaluation is the key element of any measurement [2]. Using in the mathematical model of the measuring task the mathematical minimum number of characteristic points of the measured workpiece and expressing the deviation as the function of difference of the coordinates of the characteristic points enables analytical evaluation of uncertainty of coordinate measurement fully consistent with the GUM requirements [3]. The presented algorithms were tested and used to develop the special software. The software is fully consistent with the rules of geometrical product specifications described in ISO 1101 [4].

### References

- [1] W. JAKUBIEC: Analytical estimation of uncertainty of coordinate measurements of geometric deviations. Models based on distance between point and straight line. *Advances in Manufacturing Science and Technology*, **33**(2009)2, 31-38.
- [2] A. GESSNER, R. STANIEK: Evaluation of accuracy and reproducibility of the optical measuring system in cast machine tool body assessment. *Advances in Manufacturing Science and Technology*, **36**(2012)1, 65-72.
- [3] JCGM 100:2008 Evaluation of measurement data. Guide to the expression of uncertainty in measurement.
- [4] ISO 1101:2012 Geometrical product specifications (GPS). Geometrical tolerancing. Tolerances of form, orientation, location and run-out.

*Received in November 2013*