

Real-time implementation of multiple model based predictive control strategy to air/fuel ratio of a gasoline engine

SIAWOMIR WOJNAR, TOMÁŠ POLÓNI, PETER ŠIMONČIČ, BORIS ROHAL'-ILKIV,
MAREK HONEK and JOZEF CSAMBÁL

Growing safety, pollution and comfort requirements influence automotive industry ever more. The use of three-way catalysts in exhaust aftertreatment systems of combustion engines is essential in reducing engine emissions to levels demanded by environmental legislation. However, the key to the optimal catalytic conversion level is to keep the engine air/fuel ratio (AFR) at a desired level. Thus, for this purposes more and more sophisticated AFR control algorithms are intensively investigated and tested in the literature. The goal of this paper is to present for a case of a gasoline engine the model predictive AFR controller based on the multiple-model approach to the engine modeling. The idea is to identify the engine in particular working points and then to create a global engine's model using Sugeno fuzzy logic. Opposite to traditional control approaches which lose their quality beside steady state, it enables to work with satisfactory quality mainly in transient regimes. Presented results of the multiple-model predictive air/fuel ratio control are acquired from the first experimental real-time implementation on the VW Polo 1390 cm^3 gasoline engine, at which the original electronic control unit (ECU) has been fully replaced by a dSpace prototyping system which execute the predictive controller. Required control performance has been proven and is presented in the paper.

Key words: model predictive control, multiple models, air/fuel ratio, spark ignition engine, ARX models

1. Introduction

A run of a spark ignition engine (SI) is highly dependent on the mixture of the sucked air and injected fuel present in the cylinder, waiting to be ignited by a spark. Incorrect ratio of this two components may lead to poor engine performance, ineffective functionality of the catalytic converter resulting in a higher level of emissions polluting the environment and in an extreme case this can lead to engine stoppage. Due to this

The Authors are with Department of Automation, Measurement and Applied Informatics, Mechanical Engineering Faculty, Slovak University of Technology, Bratislava, Slovak Republic. Corresponding author is B. Rohal'-Ilkiv, e-mail: boris.rohal-ilkiv@stuba.sk

The work has been supported by the Slovak Research and Development Agency under grants LPP-0075-09, APVV-0280-06 and LPP-0096-07. This support is very gratefully acknowledged.

Received 8.11.2012.

reason it is crucial to keep the air/fuel ratio (AFR) at the stoichiometric level, which means, that both the air and the fuel are completely combusted. Due to above mentioned reasons and all time tightening emission standards the car producers are improving the control of the air/fuel ratio.

Traditional control of air/fuel ratio is based on a feedforward control using predefined tables determining how much fuel has to be injected into a cylinder, based on the information from the mass air flow meter. This fuel amount is subsequently corrected using the information from the lambda probe, so the stoichiometric mixture can be reached. Due to the lambda probe position (at the engine exhaust) a delay is present, causing an improper feedback correction at the unstable engine regimes, like acceleration, or deceleration. On the other side, this kind of control guarantees stability and robustness at all conditions and therefore is still preferred by car producers, despite its disadvantages in control. The academic field has started to publish other kinds of air/fuel control strategies, mostly model-based ones. The model-based approaches are bringing good quality of control, but are also more sensitive to the model precision and issues with stability and robustness appear. A survey through popular "mean value engine modeling" is described in [2]. This analytical way of engine modeling is very clear, but requires exact knowledge of the system and the model error has to be taken into account explicitly. Other ways of model acquisition are based on an experimental identification (black box modeling). Works of [14], [15] and [4] are specialized in employment of neural networks, while [7] uses for engine modeling CARIMA models. In the engine air/fuel control have become popular fuzzy logic ([4]), neural network control ([1]) and model predictive control (MPC) approaches also ([5] and [10]). In MPC considerations the related topics on stability and robustness issues can be found e.g. in [8], or [13].

Our approach, introduced in [12] is utilizing an analytical model based predictive controller with terminal state penalization. It uses a multi-model approach based on a weighted net (Sugeno-type fuzzy logic) of autoregressive (ARX) models as a system model. The ARX models were identified in particular working points of the engine as black box models. This method of engine modeling offers an easy way of "global non-linear system model" acquisition with subsequent utilization in the model based system control. The obtained preliminary real-time control results presented in this paper indicate that the proposed predictive controller could be a suitable alternative toward the air/fuel ratio control via look-up tables.

2. Air/fuel ratio

The model of the air/fuel ratio dynamics λ of a spark ignition engine is defined as a mass ratio of the air and fuel present in a cylinder at a time instance k . Due to the fact, that the air mass flow is measured as an absolute value, it is necessary to integrate this amount during the particular time and express the air and fuel quantity as relative mass

(grams/cylinder). Hence, the air/fuel ratio is defined, as:

$$\lambda(k) = \frac{m_a(k)}{m_f(k)} \frac{1}{L_{th}} \quad (1)$$

where $m_a(k)$ and $m_f(k)$ are relative mass amounts of air and fuel in a cylinder and $L_{th} \approx 14.64$ is the theoretical amount of air necessary for the ideal combustion of a unit amount of fuel. The L_{th} constant normalizes the ideal value of λ to be 1.0.

3. SI engine modeling using ARX models

The engine modeling is based on the weighted linear local model with single input single output (SISO) structure [11]. The parameters of local linear ARX models with weighted validity [9] are identified to model the nonlinear dynamics of the AFR. The principle of this nonlinear modeling technique is in partitioning the engine's working range into smaller working points.

A net of local ARX models weighted for a particular working point ϕ is defined as follows:

$$\sum_{h=1}^{n_M} \rho_h(\phi(k)) A_h(q) y(k) = \sum_{h=1}^{n_M} \rho_h(\phi(k)) B_h(q) u(k) + \sum_{h=1}^{n_M} \rho_h(\phi(k)) c_h + e(k) \quad (2)$$

where the polynomials A_h and B_h

$$\begin{aligned} A_h(q) &= 1 + a_{h,1}q^{-1} + \dots + a_{h,n_y}q^{-n_y} \\ B_h(q) &= b_{h,1+d_h}q^{-1-d_h} + \dots + b_{h,n_u+d_h}q^{-n_u-d_h} \end{aligned} \quad (3)$$

are of the operator q^{-i} which denotes a sample delay i.e. $q^{-i}y(k) = y(k-i)$; $a_{h,i}$ and $b_{h,(j+d_h)}$ are parameters of h^{th} local function and d_h is its delay. Parameter n_M represents the number of local models. The ρ_h denotes a weighting function of a particular ARX model (see Sec. 3.1) and the $e(k)$ is a stochastic term with white noise properties. The engine working point itself is defined by engine revolutions n_{en} and the throttle valve position t_r , hence: $\phi(k) = [n_{en}(k), t_r(k)]^T$. The absolute term \hat{c}_h of the equation is computed from the steady state values of the system output $y_{e,h}$ and the system input $u_{e,h}$, as:

$$\hat{c}_h = y_{e,h} + y_{e,h} \sum_{i=1}^{n_y} \hat{a}_{h,i} - u_{e,h} \sum_{j=1}^{n_u} \hat{b}_{h,j}. \quad (4)$$

The model output is computed from the equation:

$$y_s(k) = \sum_{h=1}^{n_M} \rho_h(\phi(k)) \left(\sum_{i=1}^{n_y} \hat{a}_{h,i} q^{-i} y_s(k) + \sum_{j=1}^{n_u} \hat{b}_{h,(j+d_h)} q^{-j-d_h} u(k) + \hat{c}_h \right) \quad (5)$$

which after introduction of the estimated parameter vector $\hat{\theta}_h$ and the regression vector $\gamma(k)$, takes the following form:

$$y_s(k) = \gamma^T(k) \sum_{h=1}^{n_M} \rho_h(\phi(k)) \hat{\theta}_h + \sum_{h=1}^{n_M} \rho_h(\phi(k)) \hat{c}_h. \quad (6)$$

3.1. Weighting functions

The full working range of the engine has been covered by a discrete amount of local linear models (LLMs), identified at the particular working points. The LLMs are being weighted by the weighting functions defining validity of each local model according to instantaneous working point of the engine. Due to a requirement of a smooth and continuous global engine model, the design of these weighting functions was crucial.

There were designed particular interpolation functions for every LLM, assigning them perfectly at the belonging working point with a decreasing tendency in the directions of the deviation of the throttle valve opening Δt_r and the engine revolutions Δn_{en} from the particular working point. "Three dimensional" Gaussian functions:

$$\tilde{\rho}_h(\phi(k)) = \exp \left[- \begin{bmatrix} \Delta n_{en}(k) & \Delta t_r(k) \end{bmatrix} \begin{bmatrix} \frac{1}{\sigma_{h,1}^2} & 0 \\ 0 & \frac{1}{\sigma_{h,2}^2} \end{bmatrix} \begin{bmatrix} \Delta n_{en}(k) \\ \Delta t_r(k) \end{bmatrix} \right] \quad (7)$$

were used as the local weighting functions, due to their suitable structure fulfilling the approximation properties. Tuning parameters $\sigma_{h,1} = 250$ and $\sigma_{h,2} = 0.8$ used in the weighting functions have been chosen experimentally, assuring output of the modeled system to be continuous and smooth. At the same time the experiments have shown, that identical weighting functions can be used for weighting the air and fuel path parameters.

All the weighting functions were finally normalized by creating normalizing weighting functions:

$$\rho_h(\phi(k)) = \frac{\tilde{\rho}_h(\phi(k))}{\sum_{h=1}^{n_M} \tilde{\rho}_h(\phi(k))}, \quad (8)$$

so the sum of values of all weighting functions belonging to a particular working point (Fig. 1), equals exactly one: $\sum_{h=1}^{n_M} \rho_h(\phi(k)) = 1$.

3.2. Model identification

Considering the $\lambda(k)$ modeling, the engine has been divided into two subsystems with independent inputs, namely:

- air path* with the air throttle position as the disturbance input, and
- fuel path* with the input of fuel injector opening time.

Another disturbance-like acting quantity in the air path were engine revolutions, implicitly included in the engine model, particularly for each working point.

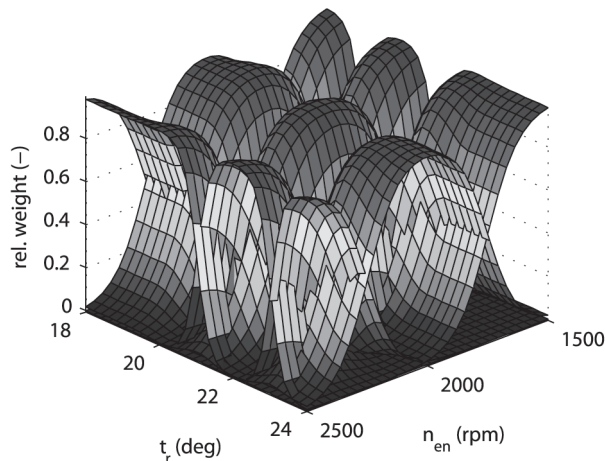

Figure 1. Relative weighting Gaussian functions

Parameters of the local ARX models have been estimated using data acquired from the exhaust gas oxygen sensor (λ_a , λ_f) and the air flow sensor. The identification has been designed so that the dynamics of the air path and the fuel path remained uncoupled, hence the dynamics of both paths were measured indirectly.

3.2.1. Fuel path identification

The identification of the fuel path dynamics has been done similarly, but with the fixed throttle valve delivering a constant air mass $m_{a,e}$, see Fig.2. Pseudo random binary signal (PRBS) was varying the fuel injectors' opening time and the value of λ_f was measured again.

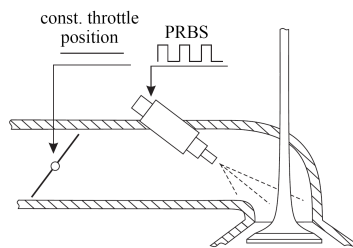

Figure 2. Pulse width excitation with PRBS

3.2.2. Air path identification

The first experiment started at the stoichiometric value of λ_a in the operation point ϕ . To excite the air path dynamics, the throttle valve position was oscillating around its steady position according to PRBS, while the fuel injectors were delivering constant fuel

mass $m_{f,e}$, see Fig. 3. The change in λ_a value has been recorded. During the experiment the engine was braked at a constant revolutions.

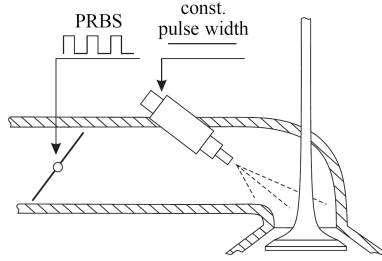

Figure 3. Pulse width excitation with PRBS

In both experiments it was necessary to wisely propose a PRBS, so that the air/fuel mixture is always ignitable.

Local ARX models can be subsequently determined from the measured values of instantaneous $\lambda_a(k)$ and $\lambda_f(k)$ belonging to the air path and fuel path, utilizing relative air and fuel mass densities:

$$m_a(k) = m_{a,e}(\phi)\lambda_a(k) \quad (9)$$

and

$$m_f(k) = \frac{m_{f,e}(\phi)}{\lambda_f(k)}. \quad (10)$$

The final formula describing the air/fuel ratio dynamics is build from local linear ARX models of the air and fuel paths in the form:

$$\lambda_s(k) = \frac{1}{L_{th}} \left[\frac{\gamma_a^T(k) \sum_{h=1}^{n_A} \rho_{a,h}(\phi(k)) \hat{\theta}_{a,h} + \sum_{h=1}^{n_A} \rho_{a,h}(\phi(k)) \hat{c}_{a,h}}{\gamma_f^T(k) \sum_{h=1}^{n_F} \rho_{f,h}(\phi(k)) \hat{\theta}_{f,h} + \sum_{h=1}^{n_F} \rho_{f,h}(\phi(k)) \hat{c}_{f,h}} \right] \quad (11)$$

where:

- γ is the regression vector of system inputs and outputs,
- n_A is the amount of working points,
- ρ is the interpolation function,
- ϕ is the vector of a working point,
- θ is the vector of ARX parameters,
- c is the absolute term of an ARX model.

In accordance with the presented general model structure, the key variables are defined in the Table 6.

Table 6. Symbol connection between the general expression and the model

general symbol	air-path model	fuel-path model	operating point
$y(k)$	$m_a(k)$	$m_f(k)$	
$u(k)$	$t_r(k)$	$u_f(k)$	
$\gamma(k)$	$\gamma_a(k)$	$\gamma_f(k)$	
$\hat{\theta}_h$	$\hat{\theta}_{a,h}$	$\hat{\theta}_{f,h}$	
$\rho_h(\phi(k))$	$\rho_{a,h}(\phi(k))$	$\rho_{f,h}(\phi(k))$	
\hat{c}_h	$\hat{c}_{a,h}$	$\hat{c}_{f,h}$	
$\phi(k)$			$[n_e(k), t_r(k - \delta)]^T$

4. Predictive control

The strategy of an "exceeding oxygen amount" control using a predictive controller is based on a prediction of a controlled quantity λ and subsequent minimization of a chosen cost function on the horizon N_p expressed in a standard quadratic form. The value of λ is predicted by utilizing partially linear models of the air and fuel path. Through the independent air path model the proper amount of fuel is predicted and enters the cost function J . Hence, the target of the cost function minimization is to determine a control law, such that the measured system output λ is stoichiometric. The second modeled subsystem, the fuel-path, is an explicit component of the objective function where the amount of fuel is a function of optimized control actions ([11]).

4.1. State-space prediction model

The applied control strategy is based on the knowledge of the internal model (IM) of air-path, predicting the change of air flow through the exhaust pipe, and consequently, setting the profile of desired values of the objective function on the control horizon. In this case we will consider the state space (SS) formulation of the system and therefore it is necessary to express linear local ARX models in the SS structure with time varying parameters:

$$\begin{aligned}
 x_{(a,f)}(k+1) &= A_{(a,f)}(\phi)x_{(a,f)}(k) + B_{(a,f)}(\phi)u_{(a,f)}(k), \\
 m_{s,(a,f)}(k) &= C_{(a,f)}x_{(a,f)}(k).
 \end{aligned}
 \tag{12}$$

The weighted parameters of multi-ARX models are displayed in matrices $A_{a,f}$ and $B_{a,f}$ for both subsystems. This is a non-minimal SS representation which advantage is that no state observer is needed. The "fuel pulse width control" is tracking changes of air

mass on a prediction horizon from IM of the air-path, by changing the amount of injected fuel mass. Due to tracking offset elimination, the SS model of the fuel-path (13) (index f), with its state space vector x_f , is written in augmented SS model form to incorporate the integral action:

$$\begin{aligned} \tilde{x}_f(k+1) &= \tilde{A}_f(\phi)\tilde{x}_f(k) + \tilde{B}_f(\phi)\Delta u_f(k) & (13) \\ \text{or} \\ \begin{bmatrix} x_f(k+1) \\ u_f(k) \end{bmatrix} &= \begin{bmatrix} A_f(\phi) & B_f(\phi) \\ 0 & 1 \end{bmatrix} \begin{bmatrix} x_f(k) \\ u_f(k-1) \end{bmatrix} + \begin{bmatrix} B_f(\phi) \\ 1 \end{bmatrix} \Delta u_f(k), \end{aligned}$$

$$\begin{aligned} n_{s,f}(k) &= \tilde{C}_f\tilde{x}_f(k) + D_f\Delta u_f(k) & (14) \\ \text{or} \\ m_{s,f}(k) &= \begin{bmatrix} C_f & D_f \end{bmatrix} \tilde{x}_f(k) + D_f\Delta u_f(k). \end{aligned}$$

The prediction of the air mass (\underline{m}_a) on the prediction horizon (N_p) is dependent on the throttle position (\underline{t}_r) and is computed as

$$\underline{m}_a(k) = \Gamma_a(\phi)x_a(k) + \Omega_a(\phi)\underline{t}_r(k-1) \quad (15)$$

where the x_a denotes the state space vector of the air path.

Due to unprecise modeling (IM strategy), the biased predictions of the air mass future trajectory and consequently biased fuel mass might occur. This error $d(k)$ is compensated incorporating the term $L[\hat{m}_f(k) - m_{s,f}(k)]$ into the fuel mass prediction equation:

$$\underline{m}_f(k) = \Gamma_f(\phi)\tilde{x}_f(k) + \Omega_f(\phi)\Delta \underline{u}_f(k-1) + d(k). \quad (16)$$

The matrices of the free response Γ_a , Γ_f and forced response Ω_a , Ω_f are computed from the SS model (13), respectively [6]. Since only $\lambda(k)$ is measurable in the equation (1), the value of $m_a(k)$ needs to be substituted using IM of the air-path, then:

$$\hat{m}_f(k) = \frac{1}{L_{th}} \frac{m_{s,a}(k)}{\lambda(k)}. \quad (17)$$

The estimate $\hat{m}_f(k)$ is used to compensate for possible bias errors of predicted $\underline{m}_f(k)$ in (16).

4.2. Problem's solution

The net of models presented in the Section 3 creates the nonlinear model. However each of the models is essentially linear. For this case, the minimum of the cost function, which has a quadratic form and does not have any constraints, has only one minimum. Thus if we assume that the function's derivative is equal to zero in the function's

minimum and that there is only one minimum, then we can pre-compute the analytical solution of the control.

The following cost function (18) encompasses deviations of predicted fuel mass amounts between the air and fuel path (based on (1)); a penalization of control increments r ; and a penalization p of a deviation between the predicted and desired final state:

$$J_\lambda = \left\| \frac{\underline{m}_a(k)}{L_{th}} - \underline{m}_f(k) \right\|_2^2 + r \|\Delta \underline{u}_f(k-1)\|_2^2 + p \|\tilde{x}_f(N) - \tilde{x}_{f,r}(N)\|_2^2. \quad (18)$$

The preferred MPC approach utilizes the state space representation with integral control and with the term $d(k)$ for corrections of predictions.

Due to a disturbance, the steady state values of u and x have to be adapted in a way that the assumption $J = 0$ is valid. This problem solves an explicit inclusion of the disturbance into the model.

The fuel injectors are controlled by a fuel pulse width, which is at the same time the control u_f . The optimal injection time can be computed by a minimization of the cost function (18), which will have after expanding by the fuel path prediction equation, form:

$$J_\lambda = \left\| \frac{\underline{m}_a}{L_{th}} - \Gamma_f \tilde{x}_f(k) - \Omega_f \Delta \underline{u}_f(k-1) - d(k) \right\|_2^2 + r \|\Delta \underline{u}_f(k-1)\|_2^2 + p \|\tilde{x}_f(N) - \tilde{x}_{f,r}(N)\|_2^2 \quad (19)$$

An analytical solution of $\frac{dJ_\lambda}{d\Delta \underline{u}} = 0$ of (20) without constraints leads to an expression determining the change of "fuel injector opening time" in a step (k), as:

$$\Delta u = (\Omega^T \Omega + Ir + p\Omega_{xN}^T \Omega_{xN})^{-1} [\Omega^T [w(k) - \Gamma \tilde{x}(k) - d(k)] - p\Omega_{xN}^T A^N \tilde{x}(k) + p\Omega_{xN}^T \tilde{x}_{f,r}(N)]. \quad (20)$$

Hence, the absolute value of the control action in a step k is given as a sum of a newly computed increment in the control (21) and an absolute value of the control in step ($k-1$):

$$u_f(k) = u_f(k-1) + \Delta u_f(k). \quad (21)$$

5. Rapid Control Prototyping system

The computational unit necessary for the real-time implementation of the MPC control is based on a powerful and freely programmable control system based on *dSpace* and *RapidPro* units; or "Rapid Control Prototyping" system" (RCP), (Fig. 4, [3]). This

is built on the processor board *ds1005* which is the main processing unit based on the IBM PowerPC 750GX processor. The RCP ensures sufficient headroom for the real-time execution of complex algorithms ([1]) and lets all engine tasks to be controlled directly. Also, the customized variants of the controller can be performed immediately.

Typical RCP system consists of:

- a math modeling program (prepared in Simulink),
- symbolic input/output blocks,
- a real-time target computer (embedded computer with an analog and digital I/O),
- a host PC with communication links to target computer,
- a graphical user interface (GUI) which enables to control the real time process.

The RCP system enables to use a support in the form of embedded functions which make the preparation of algorithms simple and fast. It is a great help, because one can concentrate on important problems as developing and debugging the algorithms rather than waste a time on less important tasks e.g. how to handle features of RCP system at low level programming.

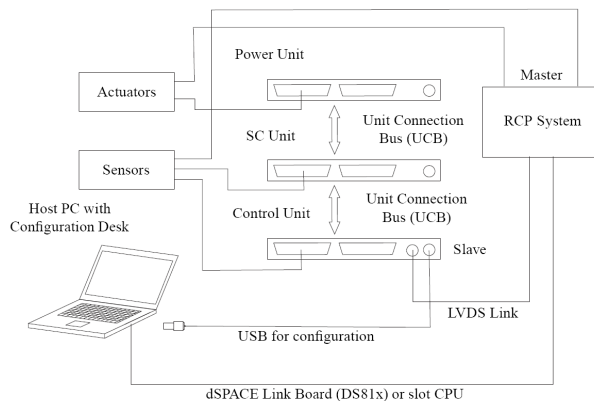

Figure 4. Rapid control prototyping scheme

6. Real-time application of a predictive control

The ability to control the mixture concentration at the stoichiometric level using the studied MPC is demonstrated through the real-time SI engine control (Fig. 5).

This has been performed using the AFR predictive control strategy described in the previous section, designed in *Matlab/Simulink* environment and compiled as a real-time

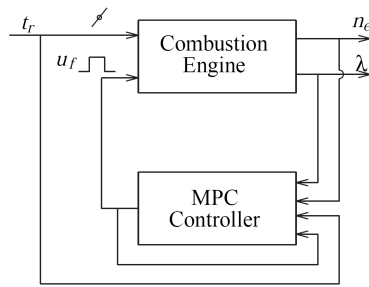

Figure 5. Control scheme

application for a *dSpace* platform. It has been applied to the VW Polo engine (Fig. 6), 1390 cm³ with 55kW@5000 rpm, not equipped with a turbocharger or an exhaust gas recirculation system. The control period was 0.2s. The result of an identification are 9 local linear models (LLM) for each, air and fuel path, dependent on a throttle valve opening and engine revolutions.

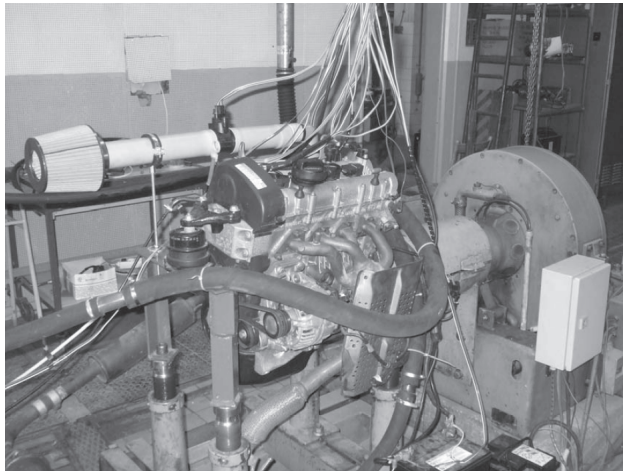

Figure 6. SI engine on a test bench

The primary aim of the control (Fig. 7) was to keep the air/fuel ratio in a stoichiometric region ($\lambda = 1$), in the worst case to keep the mixture ignitable ($0.7 \leq \lambda \leq 1.2$). During the experiment, the change in the throttle valve opening, between 21 and 22 degrees (variable t_r in Fig. 7) and the change of engine revolutions (variable n_{en}), has been performed several times. These changes simulate varying working regimes of an engine, which are adapting its run to a daily traffic. Changes in t_r and n_{en} quantities are determining the engine load, at the same time, ensuring, that the engine passes through several working points during its operation. As mentioned in Section 3, the engine revolutions are not included among explicit variables of local models, but they form together

with a delayed throttle valve position a vector of an working point $\phi(k)$. The quality of control is sufficient (variable λ in Fig. 7), with exceptional acceptable overshoots in both directions. These overshoots of the controlled variable λ have been caused by a lower model precision, due to its distance from the working point, at which the system identification has been performed. This effect is caused by the approximation of a particular model from the other working points' models. The corresponding control (fuel injection time) computed by the controller is shown in Fig. 7 as variable t_{inj} . Before experiments the initial engine warm-up (to 80 °C) has eliminated model-plant mismatch caused by temperature dependent behavior of the engine.

The control has been performed also by choosing the penalization $r = 0.1$. Utilizing the member $p \|\tilde{x}_f(N) - \tilde{x}_{f,r}(N)\|_2^2$ of the cost function by setting $p = 1.0$ allowed us to shorten the control horizon to $N_p = 20$ what significantly unloaded the computational unit and stabilized the controlled output of the engine on this shortened horizon as well, see Fig.8. The best control has been achieved in the neighborhood of working points, what is logically connected with the higher precision of the used engine model at those points. In other working points the control is still good enough, with small deviations from the stoichiometric mixture.

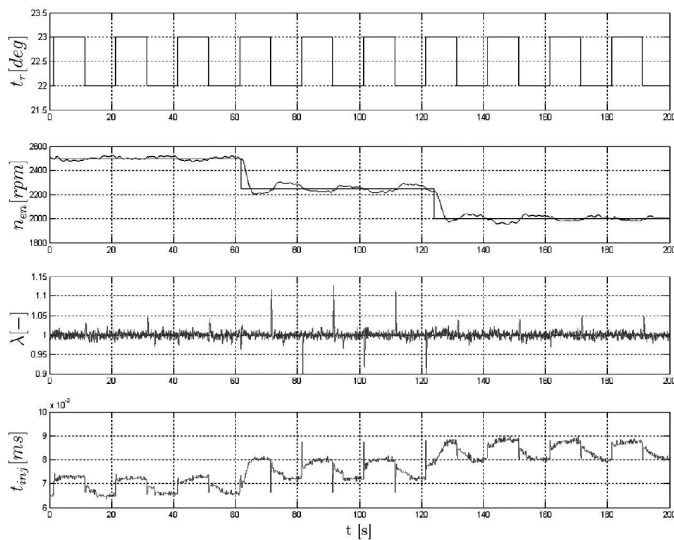

Figure 7. Results of the engine AFR predictive control without terminal state penalization

7. Conclusion

Considering the first preliminary results obtained from the reported real-time experiments carried out on the tested engine, it can be concluded, that the idea of the AFR

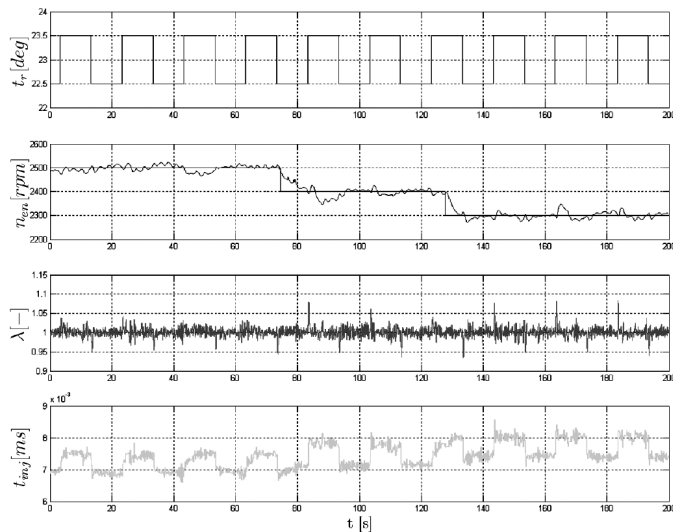

Figure 8. Results of the engine AFR predictive control with terminal state penalization

multi-model predictive control based on local ARX models is suitable and applicable for SI engines control. The proposed flexible design of the predictive controller offers easy tuning possibilities and potentially higher accuracy by extension of the studied global nonlinear engine model into the engine broader working regimes with more operating points. Therefore the next project step shall be the λ overshoots elimination by using the wider net of the local linear engine models and also active implementation of the process constraints.

References

- [1] I. ARSIE, S.D. IORIO, G. NOSCHESI, C. PIANESE and M. SORRENTINO: Optimal air-fuel ratio. *dSpace Magazine*, **1** (2008), 20-23.
- [2] J. BENGTTSSON, P. STRANDH, R. JOHANSSON, P. TUNESTAL, and B. JOHANSSON: Hybrid modeling of homogenous charge compression ignition (HCCI) engine dynamics – a survey. *Int. J. of Control*, **80**(11), (2007), 1814-1847.
- [3] dSPACE GmbH. *HelpDesk Application*. (2009).
- [4] Z. HOU: Air fuel ratio control for gasoline engine using neural network multi-step predictive model. *3rd Int. Conf. on Intelligent Computing*, Qingdao, China, (2007).

- [5] G. LORINI, A. MIOTTI and R. SCATTOLINI: Modeling, simulation and predictive control of a spark ignition engine. In Predimot (Ed.), *Predictive control of combustion engines*, 39–55. TRAUNER Druck GmbH & CoKG, (2006).
- [6] J.M. MACIEJOWSKI: *Predictive control with constraints*. University of Cambridge, 2000.
- [7] X. MAO, D. WANG, W. XIAO, Z. LIU, J. WANG and H. TANG: Lean limit and emissions improvement for a spark-ignited natural gas engine using a generalized predictive control (GPC)-based air/fuel ratio controller. *Energy & Fuels*, **23** (2009), 6026-6032.
- [8] D.Q. MAYNE, J.B. RAWLINGS, C.V. RAO and P.O.M. SCOKAERT: Constrained model predictive control: Stability and optimality. *Automatica*, **36** (2000), 789-814.
- [9] R. MURRAY-SMITH and T.A. JOHANSEN: *Multiple model approaches to modelling and control*. Taylor & Francis, 1997.
- [10] K.R. MUSKE and J.C.P. JONES: A model-based SI engine air fuel ratio controller. *American Control Conf.*, Minneapolis, USA, (2006).
- [11] T. POLÓNI, T.A. JOHANSEN and B. ROHAL' -ILKIV: Identification and modeling of air-fuel ratio dynamics of a gasoline combustion engine with weighted arx model network. *Trans. of the ASME (Journal of Dynamic Systems, Measurement, and Control)*, **130**(6), (2008). 061009.
- [12] T. POLÓNI, B. ROHAL' -ILKIV and T.A. JOHANSEN: Multiple ARX model-based air-fuel ratio predictive control for SI engines. In *IFAC Workshop on advanced fuzzy and neural control*. Valenciennes, France, Conference paper MO5-3, (2007).
- [13] J. ZEMAN and B. ROHAL' -ILKIV: Robust min-max model predictive control of linear systems with constraints. *IEEE Int. Conf. on Industrial Technology*, (2003), 930-935.
- [14] Y.J. ZHAI, D-W. YU, H-Y. GUO and D.L. YU: Robust air/fuel ratio control with adaptive DRNN model and AD tuning. *Engineering Applications of Artificial Intelligence*, **23** (2010), 283-289.
- [15] Y.J. ZHAI and D.L. YU: Neural network model-based automotive engine air/fuel ratio control and robustness evaluation. *Engineering Applications of Artificial Intelligence*, **22** (2009), 171-180.