



Research paper

Safety assessment of the construction of double track tunnels underneath existing railway tunnels

Fengfeng Guo¹, Yupeng Chen², Yongjie Zhang³, Qi Feng⁴, Da Cui⁵

Abstract: The ground disturbance caused by the tunnel construction will inevitably have an impact on the upper part of the constructed tunnel structure, and the railroad tunnel requires a very high level of control over the structural settlement deformation. For the problem of double-hole tunnel under the built tunnel, this paper takes Chongqing Mingyue Mountain Tunnel under the built Shanghai-Rong Railway Paihua Cave tunnel and Zheng-Yu Railway tunnel as the engineering background, and starts from the mechanism of ground loss caused by tunnel excavation, firstly, the settlement at the height of the existing tunnel strata is obtained through theoretical analysis, and the new Mingyue Mountain Tunnel under the Shanghai-Rong Railway tunnel is determined to be a more dangerous section. Further simulate and calculate the dynamic excavation process of the new double-hole tunnel underpass, and study the settlement deformation law of the Mingyue Mountain Tunnel underpassing the Hurong Railway Tunnel. According to the requirements of railroad tunnel for settlement deformation control, the new tunnel is determined to be constructed by step method to ensure the safety of railroad tunnel. The shortcomings of the theoretical calculation are analyzed to illustrate the important role of numerical simulation in the evaluation of tunnel underpass projects.

Keywords: double-line tunnel, underpass construction, stratum settlement, repetitive disturbance, numerical simulation

¹Prof., Eng., Tunnel Engineering Company, Ltd. of CCCC, Beijing, China, e-mail: qq178535@outlook.com, ORCID: 0009-0001-4740-4438

²MSc., Eng., Power China Railway Construction Investment GroupCo., LTD, Beijing, China, e-mail: 1257112637@qq.com, ORCID: 0009-0006-4931-2162

³Prof., Eng., Tunnel Engineering Company, Ltd. of CCCC, Beijing, China, e-mail: z20060055@s.upc.edu.cn, ORCID: 0009-0008-1998-1933

⁴MSc., Eng., College of Pipeline and Civil Engineering, China University of Petroleum. Qingdao, China, e-mail: 1715877519@qq.com, ORCID: 0009-0008-2462-6602

⁵MSc., Eng., No. 7 Engineering Co., LTD, CCCC First Highway Engineering Group Co., LTD. Zhengzhou, China, e-mail: 3650599405@qq.com, ORCID: 0009-0004-7473-1030

1. Introduction

Studies have shown that when new tunnels are built too close to existing tunnels, protection measures for existing tunnels will cost about one-sixth of the project cost [1]. The prediction of ground settlement above new tunnels facilitates the prior control of the safety of structures in different stratigraphic depths. Ruizhen Fei et al. [2] studied the dynamic response of shield tunnel undercrossing existing high-speed railway tunnel, and analyzed the influence of settlement joint and steel pipe pile reinforcement on existing tunnel. Peck [3] proposed the classical formula for predicting the lateral settlement curve of the ground surface on the basis of analyzing a large number of engineering cases of actual measurement data, and many scholars [4] improved on this basis, Reilly [5] calculated the deformation of the ground surface on the basis of considering the burial depth of the tunnel. Mair [6] divided the value of the width of the settlement trough according to the nature of different strata. With the increasing demand for infrastructure in cities, tunnels are usually excavated as two-lane tunnels. The influence of the twin tunnels on each other complicates the calculation of surface settlement [7], and the surface settlement trough observed on the twin tunnels can be shifted to one side with respect to the symmetry point of the midpoint between the twin tunnels [8]. Ocak [9] and Cording [10] found from their observation of engineering examples that the asymmetric settlement trough after the excavation of the second tunnel could be caused by the interference between the two tunnels, which increases as the spacing between the two tunnels decreases. Since the second tunnel was excavated in disturbed soil, the soil disturbance factor was introduced to correct the settlement of the second tunnel [11].

The tunnel excavation process usually uses system anchors and other suspension reinforcement, and the self-supporting capacity and stress state of the rock mass is thus changed [12, 13]. In contrast to theoretical calculations, which are limited in scope by the excavation and support methods of new tunnels, numerical simulations can simulate in detail the complex excavation and support processes of new tunnels, and provide more accurate calculations of the stratigraphic conditions. For new tunnels under existing tunnels, numerical simulations are usually used to evaluate the safety of the existing tunnels before excavation, and the results are used to dynamically optimize the construction technology [14].

The rapid development of tunnel traffic urgently requires a rapid assessment of the safety of new tunnels under existing tunnel projects, especially for deeply buried mountain tunnels with complex stratigraphic conditions, it is difficult to achieve an accurate calculation of the settlement of existing tunnels by theoretical methods, so this paper is based on the Chongqing Mingyue Mountain Tunnel under the existing Hurong Railway Paihua Cave tunnel project to assess the safety of existing tunnels caused by new tunnel underpass construction.

2. Project overview

The section where the Mingyue Mountain Tunnel is located is HC07 section, with a designed tunnel building boundary height of 5.00 meters and a width of 10.25 meters. The area above the intersection of Mingyue Mountain Tunnel and the Shanghai Chengdu Railway is surrounded by

IV surrounding rock. The starting mileage of the underpass section is: left line ZK73 +100 ~ ZK73 +260, right line K73 +123 ~ K73 +283, totaling 320 m. The areas above the intersection with the Zhengzhou Chongqing Railway are all Class III surrounding rocks, and the starting mileage of the section crossing the Zhengzhou Chongqing Railway is ZK72 +874 ~ ZK73 +023 and K72 +897 ~ K73 +046, totaling 298 meters. The buried depth of the tunnel section under Mingyue Mountain passing through the Shanghai Chengdu Railway is 290 m, and the buried depth of the tunnel section passing through the Zhengzhou Chongqing Railway is 261 m. The hydrogeological conditions indicate that the underground water system of the two sections is not well-developed. Due to the small spacing between the tunnels in the underpass section and the proximity to the railway operation line, there are significant construction risks. The plan of the newly built Mingyue Mountain Tunnel crossing the Hurong Railway is shown in Fig. 1, and the elevation is shown in Fig. 2.

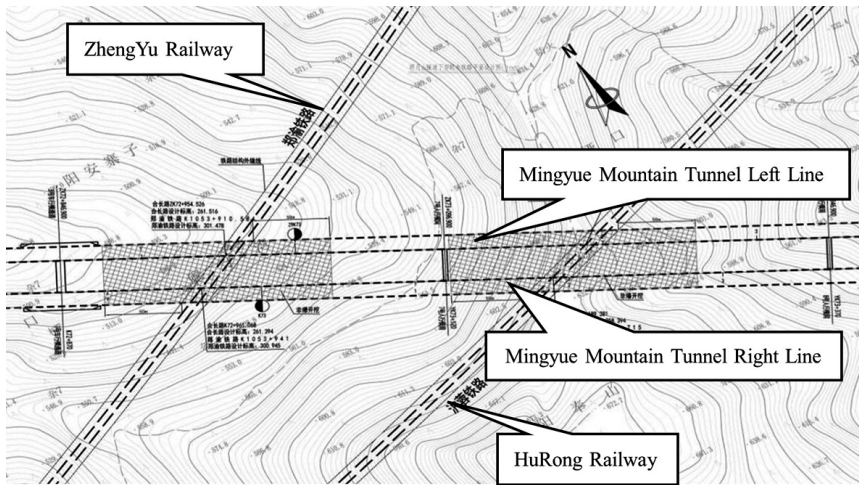

Fig. 1. Plan view of the tunnel under the Hurong Railway and Zheng-Yu Railway

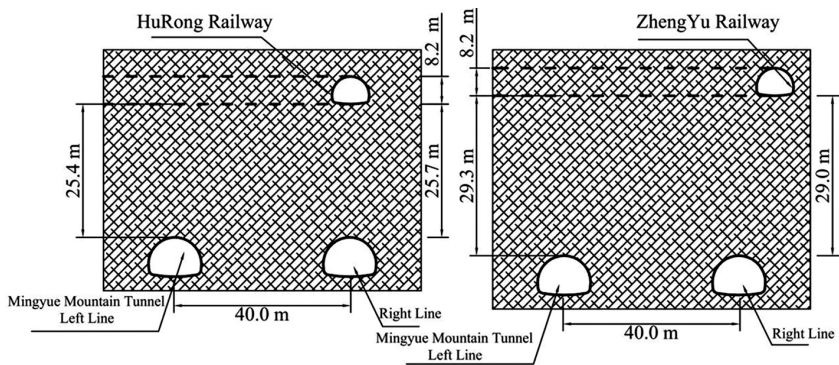

Fig. 2. Elevation of the tunnel under the Hurong Railway and Zheng-Yu Railway

Mingyue Mountain Tunnel under the Shanghai-Rong Railway Paihua Cave Tunnel plane intersection angle of about 48° , the structure of the vertical net distance of about 25.41 m. Mingyue Mountain Tunnel under the Zheng-Yu Railway Paihua Cave Tunnel plane intersection angle of about 56° , the structure of the vertical net distance of about 29.04 m. Highway design for two-way four-lane highway, the design speed of 80 km/h, the main tunnel building boundary description is shown in Table 1.

Table 1. Architectural design of new twin-tunnel building

Item	Clear width	Clear height	Lane width	Lateral width	Maintenance track
Main cave/m	10.25	5.0	3.75×2	$0.5 + 0.75$	0.75×2

Mechanical excavation was used within 50 m from the outer edge of the railroad tunnel structure. According to the preliminary design plan of Mingyue Mountain Tunnel, the underpass section tunnel is designed according to the principle of Neo-Aofa method, and the initial support adopts compound lining, mainly spray, anchor and net, and the secondary lining is molded concrete. The lining type of the underpass section is S5at type reinforced lining, and the reserved deformation of the reinforced lining section is controlled at 12 cm. the specific lining support parameters are shown in Table 2.

Table 2. Table of lining support parameters for underpassing railroad tunnel section

Type of lining		S5at lining section
Excavation method		Step method
Allowance for deformation		12 cm
Initial support	C20 early strength injection concrete	24 cm
	$\Phi 6.5$ reinforcing steel mesh	$\Phi 20 \times 20$ cm store full
	System anchors	R25 hollow grouting anchor @ 50×120 cm, $L = 3.5$ m
	Initial support reinforcement measures	I18 beam $\Phi 50$ cm
Secondary lining		55 cm C30 steel reinforcement
elevation arch		55 cm C30 steel reinforcement
Auxiliary construction measures		$\Phi 42$ overrunning small conduit @ 200×35 cm, $L = 3.5$ m
		$\Phi 76L$ self-entry anchors @ 1200×35 cm, $L = 15$ m

The shape of the Mingyue Mountain Tunnel cross section is shown in Fig. 3.

Hu Rong Railway Paihua Cave Tunnel is a double line single tunnel, Mingyue Mountain Tunnel underpass section is IV level surrounding rock, because the rock quality of the underpass

section is soft, joint fissure development, self-stabilization ability is poor, the railroad tunnel and the new tunnel intersection location range also use S5at lining, the area detailed support parameters are shown in Table 3, the tunnel is located in the same surrounding rock type as Mingyue Mountain Tunnel.

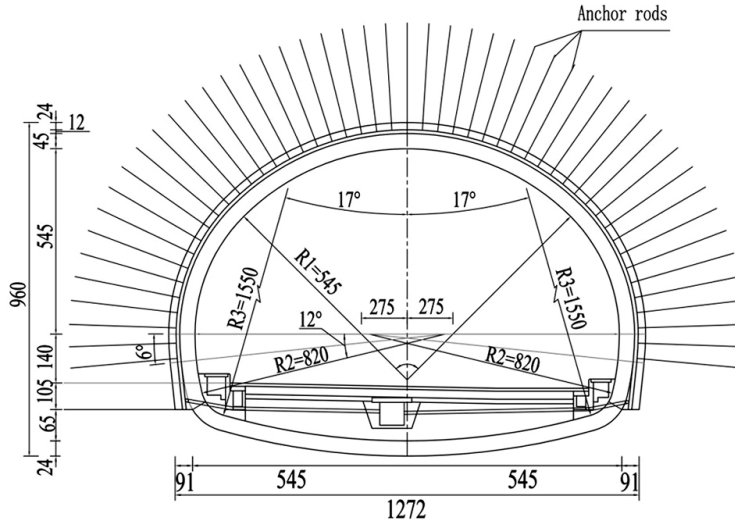

Fig. 3. Cross section of S5at reinforced lining under railroad section

Table 3. Tunnel lining and support parameters of Shanghai-Chengdu Railway

Type of lining	Spraying concrete/cm	Anchor rods (longitudinal × transverse)	Steel frame	Arches/cm	elevation arch/cm
Class V composite	27	@ 120 × 100 cm	Profiles or grids@80	50 C35 reinforced concrete	55 C35 reinforced concrete

3. Theoretical analysis of ground settlement caused by Mingyue Mountain Tunnel

3.1. Theoretical estimation method of ground settlement

The surface settlement caused by the loss of ground due to the difference in clear distance between the left and right line tunnels in a two-lane tunnel differs, defining the clear distance between the two tunnels as D , as shown in Fig. 4. The effect of double-lane tunneling on the

ground surface is the result of the combined effect of the left and right lines, since double-lane tunnels are usually excavated at staggered intervals, with the later excavation taking place in the disturbed strata. The surface settlement trough observed on a two-lane tunnel may be symmetrical with respect to the two-lane tunnel or shifted to either side, i.e. the ground loss due to the first excavation is different from the ground loss due to the later excavation. Therefore, Ocak [15] introduced a rock disturbance correction factor k on the basis of the calculation formula for predicting settlement in a two-lane tunnel proposed by O'Reilly [5]. The correction factor k increases with the increase of the tunnel diameter and decreases with the decrease of the lateral distance D between the centerlines of the two tunnels. The value of correction factor k is taken as in Eq. (3.1), and the width of surface settlement trough i is calculated as in Eq. (3.2).

$$(3.1) \quad k = 1 + \frac{2R}{D + 2R}$$

$$(3.2) \quad i = 0.9 \times R \times \left(\frac{H + R}{2R} \right)^{0.88}$$

For a horseshoe section tunnel, the equivalent radius of the tunnel is calculated by area conversion. The equivalence radius conversion formula is shown in Eq. (3.3).

$$(3.3) \quad R' = \sqrt{\frac{A}{\pi}}$$

where: A – cross-sectional area of the horseshoe-shaped tunnel

In order to predict the settlement trough curve at a certain depth of the ground, Ma [16] differentiated the left and right cavern tunnels, considered the influence of the preceding tunnel on the following tunnel, and calculated the settlement of the ground caused by the double cavern tunnel by superposition as shown in Eq. (3.4). To clearly represent the characteristics of the settlement trough curve, the center of the two-line tunnel axis is used as the coordinate origin. The maximum settlement value is calculated according to the Peck formula and introducing the concept of stratigraphic loss rate as in Eq. (3.5). The calculation of the width coefficient of settlement trough for different stratigraphic depths is shown in Eq. (3.6).

$$(3.4) \quad S(x, z) = S_{z_{\max 1}} \times \exp \left[-\frac{(x - 0.5d)^2}{2i_1^2(z)} \right] + S_{z_{\max 2}} \times \exp \left[-\frac{(x + 0.5d)^2}{2i_2^2(z)} \right]$$

$$(3.5) \quad S_{z_{\max}} = \frac{\pi R^2 \eta}{i(z) \cdot \sqrt{2\pi}}$$

$$(3.6) \quad i(z) = i \times \left(1 - \frac{H - z}{H} \right)^{-0.3}$$

where: $S_{z_{\max 1}}, S_{z_{\max 2}}$ is the maximum settlement value at z height caused by the first and second row tunnel excavation, m . $i_1(z), i_2(z)$ are the coefficients of the width of the sinkhole at distance z from the upper part of the tunnel for the first and second row tunnels, m . η is the stratigraphic loss rate.

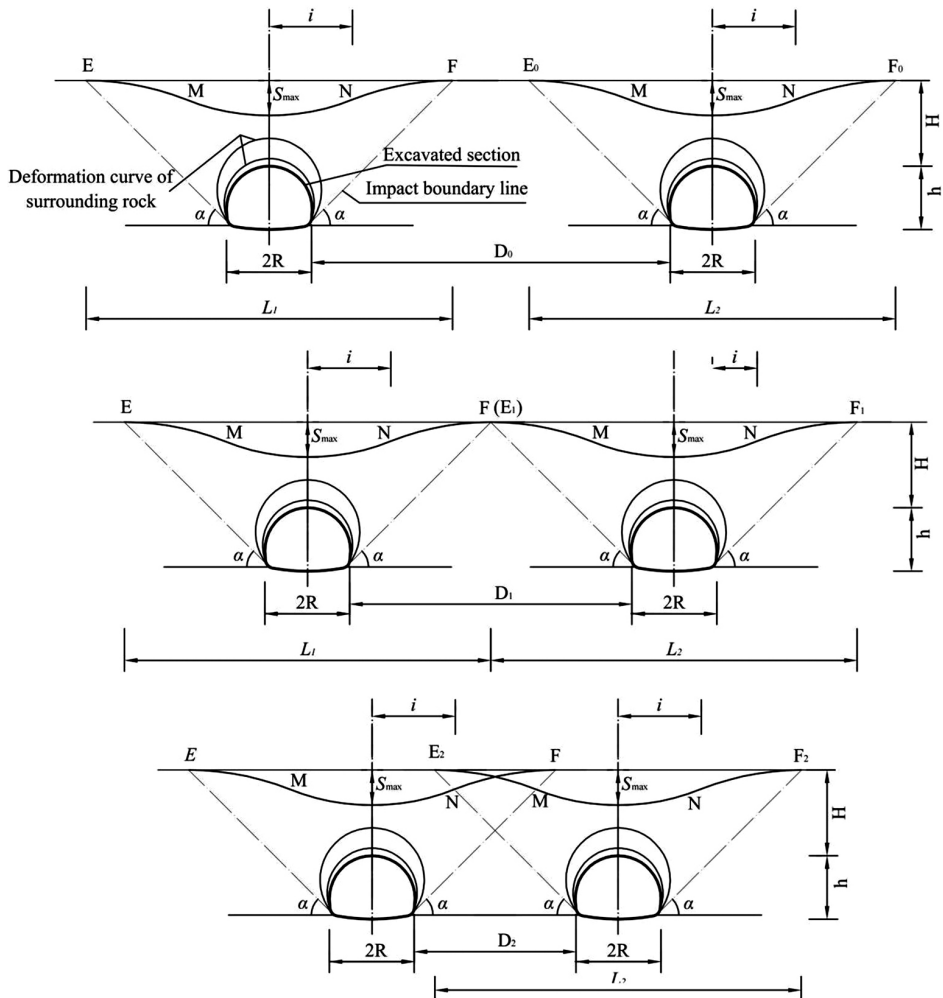

Fig. 4. Superimposed surface settlement trough curves caused by double-lane tunnel excavation with different spacing

Although Eq. (3.4) takes into account the mutual influence of successive excavation tunnels, the current research results do not make a separate distinction between the value of the stratigraphic loss rate of post-excavation tunnels, so this paper corrects the settlement caused by post-excavation tunnels in Eq. (3.4) by a correction factor k , and brings the Eq. (3.2) into Eq. (3.7). That is, the corrected settlement trough curves for different stratigraphic depths caused by the double tunnel excavation.

$$(3.7) \quad S(x, z) = \frac{\pi R^2 \eta}{i_1(z) \sqrt{2\pi}} \times \exp \left[-\frac{(x - 0.5d)^2}{2i_1^2(z)} \right] + k \times \frac{\pi R^2 \eta}{i_2(z) \sqrt{2\pi}} \times \exp \left[-\frac{(x + 0.5d)^2}{2i_2^2(z)} \right]$$

3.2. Theoretical calculation of ground settlement caused by tunnel excavation in Mingyue Mountain

The stratigraphic loss rate is related to the stratigraphic type, construction method, support method and other factors, and its value mainly depends on regional experience. In this paper, we determine the value of stratigraphic loss rate through geological data and review literature [17].

According to the settlement prediction calculation Eq. (3.7), the settlement at the corresponding stratigraphic heights in the section of Mingyue Mountain Tunnel under the Zheng-Chongqing Railway and the section of Hurong Railway is calculated, and the calculation statistics of each value in the formula are shown in Table 4.

Table 4. Theoretical calculation parameters

Parameter	k	i (m)	z (m)	$i(z)$ (m)	d (m)	η	R' (m)	$S_{z_{\max 1}}$ (m)
Undercrossing the HuRong Railway section	1.26	91.56	25.4	192.9	40	0.8%	5.2	0.00175
Undercrossing ZhengYu Railway section	1.26	72.8	29.0	128.1	40	0.6%	5.2	0.00132

The calculation results are brought into Eq. (3.7) and then simplified to obtain the expression of the settlement groove curve at the height of the existing railroad line in the double-bore tunnel section of Mingyue Mountain under the Hurong Railway and the Zheng-Yu Railway, and the image is drawn in Fig. 5.

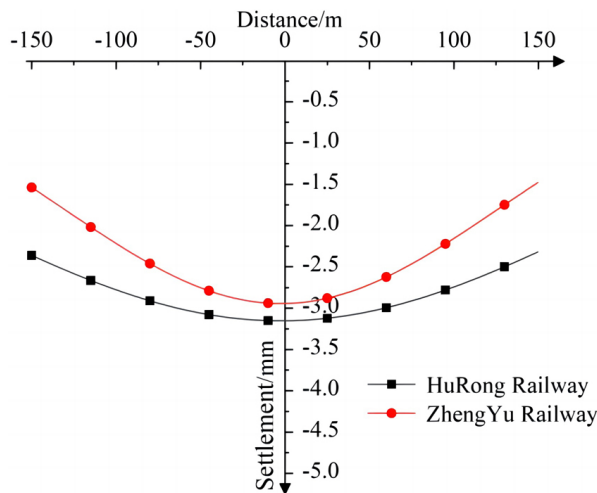

Fig. 5. Settling tank curves

4. Numerical calculation

The three-dimensional finite element model of the tunnel under the Hu Rong Railway is shown in Fig. 6. The burial depth of the tunnel section of the new tunnel under the Hu Rong Railway is about 290 m. The support structure of the tunnel under the Hu Rong Railway and the structure of the left and right lines of the new tunnel under the Hu Rong Railway are simulated using elastic solid units, and the ground stress field is considered according to the self-weight stress field.

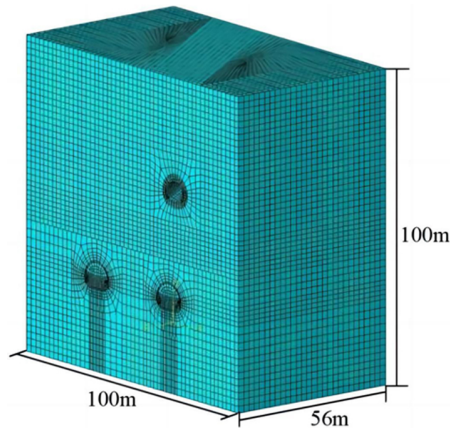

Fig. 6. Numerical model of the Mingyue Mountain Tunnel under the Hurong Railway Tunnel

In this evaluation model, displacement boundary conditions are used, and the top surface of the soil model is subjected to the equivalent load of the corresponding upper rock mass, and the bottom surface is vertically constrained and surrounded by normal constraints.

According to the distribution of rock layers in the tunnel section of Mingyue Mountain Tunnel under the Hurong Railway, the front and rear 30 m of the section under the railroad are class IV surrounding rocks, and the calculated parameters of rock and soil layers and pre-reinforced structures in the depth range of rock layers taken by the model are shown in Table 5.

Table 5. Calculation parameters of geotechnical layers

Rock properties	Mass density ($\text{kN}\cdot\text{m}^{-3}$)	Modulus of elasticity (GPa)	Poisson's ratio	Cohesion (MPa)	Angle of internal friction
Grade IV	22	2.0	0.35	0.3	28
Small conduit reinforcement area	29	2.95	0.2	0.34	39
Anchor reinforcement area	24.6	2.36	0.312	0.324	33

The calculated parameters of the concrete support structure are shown in Table 6.

Table 6. Structural calculation parameters

Materials	Modulus of elasticity E (MPa)	Poisson's ratio	Mass density ($\text{kN}\cdot\text{m}^{-3}$)
C20 spray concrete	21000	0.23	22
C30 steel reinforcement	30000	0.2	25
C15 flake concrete	26000	0.2	23

The new Mingyue Mountain double-cavern tunnel is excavated by the step method, and a finite element model is established to simulate the impact of the new tunnel construction on the existing Hurong Railway tunnel.

To study the settlement pattern of the ground when the new tunnel is excavated by the step method, four typical working conditions are set as 1, 2, 3 and 4: completion of step excavation on the left line, through the left line, completion of step excavation on the right line and through the right line, and the settlement deformation curves of the ground when the vertical clear distance from the new tunnel in the vertical plane where position 2 is located is equal to 20 m, 25 m, 30 m and 35 m, respectively, as shown in Fig. 7.

The maximum settlement values for the different depths of the strata at the time of the double line penetration are shown in Table 7. From the table, it can be seen that the maximum settlement value of the strata decays more and more slowly as the observation point gets farther and farther from the upper part of the new tunnel.

Table 7. Settlement change rate of strata at different depths during the construction

Distance z (m)	20	25	30	35
Maximum settling value (mm)	2.89	2.32	2.13	1.99
Decay rate	–	19.7%	8.2%	6.6%

In order to study the structural response of the existing tunnel when the tunnel excavation is completed, the settlement values of the existing tunnel arch bottom and arch top were extracted as shown in Fig. 8. It can be seen from the figure that when the step method is used for the underpass construction, the maximum settlement of the existing tunnel vault occurs near the intersection of the old and new tunnels, and the maximum settlement value of the vault is 2.19 mm; the maximum settlement of the vault bottom occurs near the intersection of the right line of Mingyue Mountain and the existing tunnel, and the maximum settlement value of the vault bottom is 2.31 mm, and the settlement of the vault bottom of the existing tunnel is larger than that of the vault top. The maximum differential settlement of the top of the arch within the depth of the existing tunnel is 0.17 mm, and the maximum differential settlement of the bottom of the arch is 0.20 mm.

Comparing the settlement at the height of the strata at the bottom of the arch of the built tunnel with the settlement of the built tunnel, it can be seen that the two settlement values are close to each other, so the possibility of the existence of a cavity around the lining of the built tunnel is small.

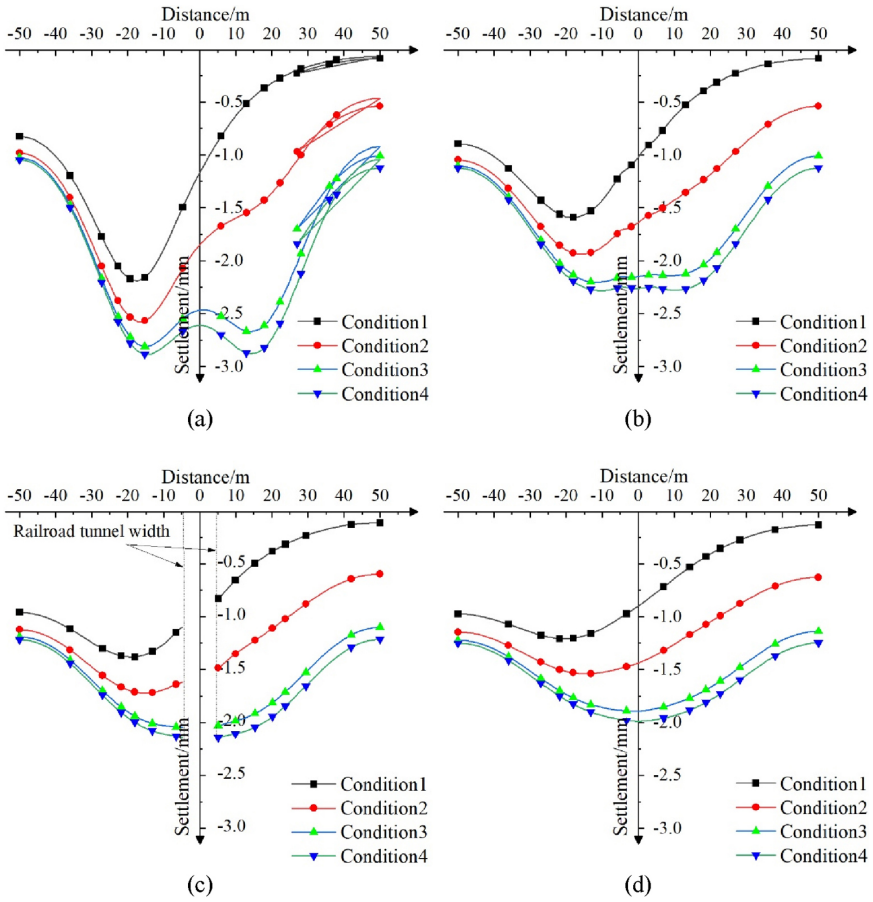

Fig. 7. Ground settlement curves at different locations above the new tunnel (Step method): a) 20 m, b) 25 m, c) 30 m, d) 35 m

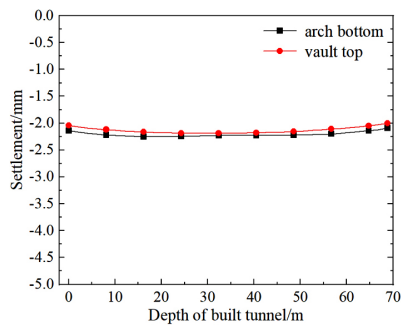

Fig. 8. Settlement curves of existing tunnel vault and arch bottom

The code stipulates that the settlement of the tunnel underpass caused by the settlement of the upper railroad tunnel should be controlled within 3.0mm, and the assessment results show that the settlement of the built railroad tunnel satisfies the control standard of the code for the settlement deformation of the lining.

5. Conclusions

Based on the settlement formula at different stratigraphic depths caused by the excavation of the horseshoe-shaped two-line tunnel derived from the peck formula, the settlement at the stratigraphic height of the built Hurong Railway Tunnel caused by the excavation of the new Mingyue Mountain Tunnel was calculated to be 3.15 mm. Analysis of the theoretical equations shows that the theoretical calculations cannot take into account the influence of the new tunnel excavation method on the ground settlement, and that the new tunnel pre-reinforcement measures will also have an impact on the settlement of the upper strata. Therefore, there are limitations in predicting the settlement at the height of the built tunnel caused by the theoretical formulae for double tunnel excavation.

Numerical calculations can highly restore the dynamic excavation process of the tunnel and analyze the impact of the tunnel construction method and support structure on the built tunnel. The numerical calculation results show that the maximum settlement of the existing tunnel structure caused by the excavation of the new double tunnel is 2.31 mm, which satisfies the settlement control standard for railroad tunnels, so the underpass section is determined to be constructed by the step method.

References

- [1] H. Lai, X. Zhao, Z. Kang, and R. Chen, "A new method for predicting ground settlement caused by twin-tunneling under-crossing an existing tunnel", *Environmental Earth Sciences*, vol. 76, no. 21, art. no. 726, 2017, doi: [10.1007/s12665-017-7079-6](https://doi.org/10.1007/s12665-017-7079-6).
- [2] R. Fei, L. Peng, C. Zhang, J. Zhang, and P. Zhang, "Mechanical characteristics of twin tunnel underneath construction on existing high-speed railway tunnel", *Archives of Civil Engineering*, vol. 69, no. 1, pp. 403–420, 2023, doi: [10.24425/ace.2023.144180](https://doi.org/10.24425/ace.2023.144180).
- [3] R.B. Peck, "Deep excavations and tunnelling in soft ground", in *Proceedings of 7th International Conference on Soil Mechanics and Foundation Engineering*. Mexico, 1969, pp. 225–290.
- [4] W. Bogusz, T. Godlewski, and A. Siemińska-Lewandowska, "Parameters used for prediction of settlement trough due to TBM tunnelling", *Archives of Civil Engineering*, vol. 67, no. 4, pp. 351–367, 2021, doi: [10.24425/ace.2021.138504](https://doi.org/10.24425/ace.2021.138504).
- [5] M. O'Reilly and B.M. New, "Settlements above tunnels in the United Kingdom—their magnitude and prediction", in *Tunneling '82' IMM London*. London, 1982, pp. 173–181.
- [6] R.J. Mair and R.N. Taylor, "Bored tunnelling in the urban environment", in *International Conference on Soil Mechanics & Foundation Engineering*. Hamburg, 1997, pp. 2353–2385.
- [7] C.R. Han, G.Z. He, and G.B. Wang, "Analysis of factors affecting surface settlement during the construction of double track parallel tunnels", *Soil Mechanics*, vol. 32, no. S2, pp. 484–487, 2011, doi: [10.16285/j.rsm.2011.s2.061](https://doi.org/10.16285/j.rsm.2011.s2.061).
- [8] X. Wang, T. von Schmettow, X. Chen, and C. Xia, "Prediction of ground settlements induced by twin shield tunnelling in rock and soil – A case study", *Underground Space*, vol. 7, no. 4, pp. 623–635, 2022, doi: [10.1016/j.undsp.2021.12.001](https://doi.org/10.1016/j.undsp.2021.12.001).

- [9] I. Ocak, "Interaction of longitudinal surface settlements for twin tunnels in shallow and soft soils: the case of Istanbul Metro", *Environmental Earth Sciences*, vol. 69, no. 5, pp. 1673–1683, 2013.
- [10] E.J. Cording, "Displacements around soft ground tunnels", in *General Report 5th Pan American Conference on Soil Mechanics and Foundation Engineering*. America, 1975, pp. 571–633.
- [11] S.G. Ercelebi, H. Copur, and I. Ocak, "Surface settlement predictions for Istanbul Metro tunnels excavated by EPB-TBM", *Environmental Earth Sciences*, vol. 62, no. 2, pp. 357–365, 2011, doi: [10.1007/s12665-010-0530-6](https://doi.org/10.1007/s12665-010-0530-6).
- [12] D.X. Meng, Z.S. Tan, and X.Y. Wang, "Centrifugal experimental study on the mechanism of anchor rod action in large cross-section loess tunnels", *Journal of Civil Engineering*, vol. 50, no. S1, pp. 36–41, 2017, doi: [10.15951/j.tmgcxb.2017.s1.007](https://doi.org/10.15951/j.tmgcxb.2017.s1.007).
- [13] G. Wei, D.Q.L. Zhao, H. Xu, Y. Zhou, and C. Chen, "Research on soil deformation caused by overlapping shield tunnel construction based on unified solution", *Journal of Central South University (Natural Science Edition)*, vol. 53, no. 2, pp. 589–598, 2012.
- [14] J. Huang, S. Tian, H. Chen, and P. Zhao, "Research on Optimization of Construction Technology for Shield Tunnel Undercrossing the Ma Liu Zhou Waterway under Complex Geological Conditions", *Construction Technology*, vol. 48, no. 7, pp. 65–69, 2019.
- [15] I. Ocak, "A new approach for estimating the transverse surface settlement curve for twin tunnels in shallow and soft soils", *Environmental Earth Sciences*, vol. 72, no. 7, pp. 2357–2367, 2014, doi: [10.1007/s12665-014-3145-5](https://doi.org/10.1007/s12665-014-3145-5).
- [16] K.S. Ma, "Research on Ground Movement and Protection of Adjacent Buildings Caused by Shield Construction", D.E. thesis, Huazhong University of Science and Technology, China, 2008.
- [17] C.S. Wu and Z.D. Zhu, "Statistical analysis of formation loss rate caused by different tunnel construction methods", *Journal of Zhejiang University (Engineering Edition)*, vol. 53, no. 1, pp. 19–30, 2019.

Received: 2023-06-28, Revised: 2023-09-21