

10.24425/acs.2022.142848

Archives of Control Sciences
Volume 32(LXVIII), 2022
No. 3, pages 557–576

Finite-time SDRE control of F16 aircraft dynamics

Marcin CHODNICKI, Paweł PIETRUSZEWSKI, Mariusz WESOŁOWSKI and Sławomir STĘPIEŃ

This paper proposes a finite-time horizon suboptimal control strategy based on state-dependent Riccati equation (SDRE) to control of F16 multirole aircraft. Flight stabilizer control of super maneuverable aircraft is modelled and simulated. For aircraft modelling purpose a full 6 DOF model is considered and described by nonlinear state-space approach. Also a stable state-dependent parametrization (SDP) necessary for solution of the SDRE control problem is proposed. Solution of the SDRE control problem with adequate defined weighting matrices in performance index shows possibility of fast and optimal aircraft control in finite-time. The method in this form can be used for stabilization of aircraft flight and aerodynamics.

Key words: aircraft modelling, state-dependent Riccati equations, finite-time optimal control

1. Introduction

Flight control of multirole fighter aircraft is viewed as a difficult and problematic area of aerospace engineering, primarily since it has a track record associated with program delays, and aircraft incidents and accidents [34–36]. Modern and innovative aircraft are equipped with robust and optimal controllers, LQG/LTR in longitudinal control for instance. But, the primary purpose of a flight control system is to provide the appropriate interface between a pilot and the aircraft responses. Although stabilization is a requirement of a typical modern FCS (Flight Control Systems), it is stabilization with a pilot in the loop, or flying qualities,

Copyright © 2022. The Author(s). This is an open-access article distributed under the terms of the Creative Commons Attribution-NonCommercial-NoDerivatives License (CC BY-NC-ND 4.0 <https://creativecommons.org/licenses/by-nc-nd/4.0/>), which permits use, distribution, and reproduction in any medium, provided that the article is properly cited, the use is non-commercial, and no modifications or adaptations are made

M. Chodnicki, P. Pietruszewski and M. Wesołowski are with Air Force Institute of Technology, Księcia Bolesława 6, 01-494 Warsaw, Poland.

S. Stępień (corresponding author, e-mail: slawomir.stepien@put.poznan.pl) is with Poznan University of Technology, Institute of Automatic Control and Robotics, Piotrowo 3a, 60-965 Poznań, Poland.

We would like to express our sincere appreciation to flight instructor and aerobatic pilot Tadeusz Zaworski from Air Force Institute of Technology in Warsaw and Lt.-Col. pilot Adam Wójcik from Krzesiny NATO Air Base for their valuable and constructive talks, suggestions and comments during writing and development of this research work.

Received 17.01.2022. Revised 11.08.2022.

that is the design challenge and has caused most problems [1, 29, 36]. The relationship between pilot action and aircraft reaction should be fast, performed in finite time, eliminating aerodynamics nonlinearities, uncertainties or uncontrollable oscillations resulting from efforts of the pilot to control the aircraft and occur when the pilot of an aircraft inadvertently commands an often increasing series of corrections in opposite directions, known as PIO (Pilot Involved Oscillations) [19, 36].

One of popular and very effective is a single-engine multirole fighter aircraft F16 originally developed by General Dynamics for the United States Air Force (USAF) also used by Polish Air Force (PAF). The multirole F16 aircraft is shown in Fig. 1.



Figure 1: F16 multirole fighter aircraft [37]

Many papers deal with the F16 aircraft dynamics, where finite-time optimal control methods used to flight control systems is still a challenge for many engineers and researchers [1, 18, 22, 23, 29, 34, 35]. Literature provide some interesting works related to finite-time problems. In [12] authors studied a finite-time sliding mode attitude controller for a reentry vehicle with blended aerodynamic surfaces and a reaction control system. Next work [29] investigated the path planning of a reusable launch vehicle using a finite-horizon suboptimal controller. Further, the paper [9] deals with digital controller for longitudinal aircraft model, where the control task is formulated as a tracking problem of velocity and flight path angle considering incomplete information about varying parameters of the system and external disturbances. The output tracking control, employing model reference feedback linearization of an aircraft subject to additive, uncertain, nonlinear disturbances is presented and described in [27]. An interesting control problem is studied in [31] where the finite-time attitude tracking

control problem of a reusable launch vehicle in the reentry phase under input constraints using a constrained adaptive back-stepping fast terminal sliding mode control technique. A nonsingular terminal sliding-mode control method with finite-time fault-tolerant control for spacecraft with actuator saturations is studied in [18].

Nowadays, modern optimal control theory proposes high performance and rapidly emerging control technique called finite-time SDRE (State-Dependent Riccati Equation) [2, 7, 20, 24, 32]. This is a suboptimal control methodology for nonlinear systems. The technique uses direct parameterization to bring the nonlinear system to a linear structure having state-dependent coefficients (SDC) [33]. A state-dependent Riccati equation (SDRE) is then solved accordingly to the change of state trajectory to obtain a nonlinear feedback controller matrix, which coefficients, in other feedback gains are the solution of SDRE [8].

The method, firstly proposed in 1962 [21] and later expanded in 1975 [32], was further carefully analyzed and deeply studied creating its useful form for technical applications [20]. The method employs parameterization of the nonlinear dynamics into the state vector, then the product of a matrix-valued function depends on the state itself [33]. The control technique fully captures the nonlinearities of the dynamic system, bringing the system to a (nonunique) linear structure having state-dependent coefficient (SDC) matrix form, and minimizing also a state-dependent nonlinear performance index having a quadratic-like structure. The differential SDRE equations using the SDC matrices is then solved on-line (in real time) to give the suboptimum control law. The technique for the finite-time nonlinear optimal control problem in the multivariable case is locally asymptotically stable and locally asymptotically optimal as described in following theoretical contributions [2, 4, 6, 16, 20].

Applications of the SDRE control technique include also satellite and spacecraft control and estimation, integrated guidance and control design, autopilot design, robotics, control of systems with parasitic effects, control of artificial human pancreas, ducted fan control and magnetic systems including levitation and drives [2, 7, 18].

In this paper, a modelling and control design methodology as the concept is proposed to design of high-performance and optimal flight stabilizer for F16 multitask military aircraft. The paper presents a nonlinear model of the aircraft and solution of the finite-time suboptimal control problem for flight stabilization problem minimizing energy lost and delivered to the flaying machine.

2. F16 nonlinear model

The rigid body equations of motion are the differential equations that describe the evolution of basic states of an aircraft. The aircraft model presents Fig. 2.

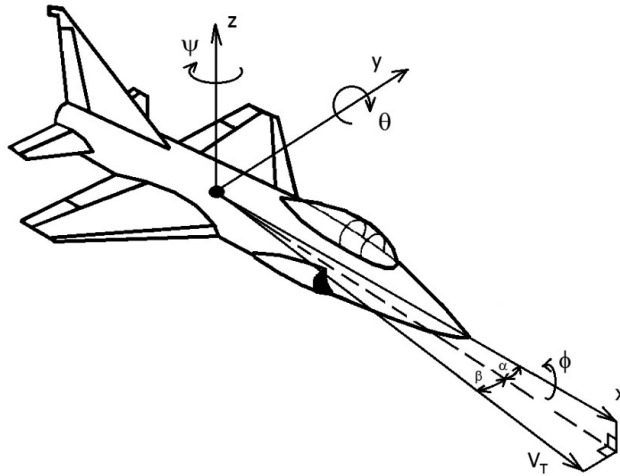

Figure 2: F16 aircraft model

The aircraft dynamics is generally defined using Newton's force and moment equations [34, 35]. The force equation is following

$$\mathbf{F} = m (\dot{\mathbf{v}} + \boldsymbol{\omega} \times \mathbf{v}), \quad (1)$$

where \mathbf{v} is an aircraft linear velocity vector, $\boldsymbol{\omega}$ is angular velocity vector, m is an aircraft mass and \mathbf{F} denotes, of course, force vector. For completeness, also moment equation should be considered. The equation describes all the moments acting on the aircraft, equal to the rate of change of angular momentum

$$\mathbf{M} = \mathbf{I}\dot{\boldsymbol{\omega}} + \boldsymbol{\omega} \times \mathbf{I}\boldsymbol{\omega}, \quad (2)$$

where \mathbf{I} is an aircraft inertia matrix and \mathbf{M} denotes moment vector. When consider vector \mathbf{v} defined for all components in x , y and z direction and $\boldsymbol{\omega}$ for roll φ , pitch θ and yaw ψ angle

$$\mathbf{v} = \begin{bmatrix} u \\ v \\ w \end{bmatrix} \quad \text{and} \quad \boldsymbol{\omega} = \begin{bmatrix} p \\ q \\ r \end{bmatrix} \quad (3)$$

then equations of aircraft aerodynamics can be defined for linear and angular speeds. In addition, because of a plane of symmetry so in the inertia matrix the cross-products involving y become zero

$$\mathbf{I} = \begin{bmatrix} I_{xx} & 0 & -I_{xz} \\ 0 & I_{yy} & 0 \\ -I_{zx} & 0 & I_{zz} \end{bmatrix}. \quad (4)$$

The system of nonlinear equations that describes aircraft flight dynamics, considering gravity forces g and force due to the thrust F_T , is following

$$\begin{bmatrix} \dot{u} \\ \dot{v} \\ \dot{w} \end{bmatrix} = \begin{bmatrix} rv - qw + g \sin \theta + \frac{1}{m} F_T \\ pw - ru - g \sin \theta \cos \theta \\ qu - pv - g \cos \theta \cos \theta \end{bmatrix}, \quad (5)$$

$$\begin{bmatrix} \dot{p} \\ \dot{q} \\ \dot{r} \end{bmatrix} = \begin{bmatrix} c_1 pq + c_2 rq + c_{lp} L + c_{np} N \\ c_3 (p^2 - r^2) + c_4 pr + c_{mq} (M + F_T Z_{TP}) \\ c_5 pq + c_6 rq + c_{lr} L + c_{nr} N \end{bmatrix}, \quad (6)$$

where L, M, N are components of the aircraft moment vector $\mathbf{M} = [L \ M \ N]^T$

$$\begin{aligned} c_1 &= (-I_{zz} I_{xz} - I_{xz} (I_{xx} - I_{yy})) / (I_{xz}^2 - I_{xx} I_{zz}), \\ c_2 &= (-I_{zz} (I_{yy} - I_{zz}) + I_{xz}^2) / (I_{xz}^2 - I_{xx} I_{zz}), \\ c_3 &= -I_{xz} / I_{yy}, \quad c_4 = -(I_{xx} - I_{zz}) / I_{yy}, \\ c_5 &= (-I_{xz}^2 - I_{xx} (I_{xx} - I_{yy})) / (I_{xz}^2 - I_{xx} I_{zz}), \\ c_6 &= (I_{xx} I_{xz} - I_{xz} (I_{yy} - I_{zz})) / (I_{xz}^2 - I_{xx} I_{zz}), \\ c_{lp} &= c_{np} = -I_{zz} / (I_{xz}^2 - I_{xx} I_{zz}), \\ c_{mq} &= 1 / I_{yy}, \\ c_{lr} &= -I_{xz} / (I_{xz}^2 - I_{xx} I_{zz}), \quad c_{nr} = -I_{xx} / (I_{xz}^2 - I_{xx} I_{zz}) \end{aligned}$$

and Z_{TP} is a position of engine thrust point.

Equations (5)–(6) are a nonlinear vector and it has to be formed as SDC matrices. Separation of (5)–(6) is not so complicated for aircraft systems, because in general, state variables are in the form of products and it make parametrization easy. Only terms related to gravity g seems to be problematic in sense of parametrization. But for the case study purpose, for example, when consider aircraft flight with nonzero speed, the terms can be parametrized by the speed in flight direction.

To describe the aircraft orientation an Euler angle relationship, in other Euler angles for flat Earth assumption, is used from the transformation from the local horizontal to the body axes. The resulting kinetic equations are

$$\begin{bmatrix} \dot{\phi} \\ \dot{\theta} \\ \dot{\psi} \end{bmatrix} = \begin{bmatrix} p + (q \sin \phi + r \cos \phi) \tan \theta \\ q \cos \phi - r \sin \phi \\ (q \sin \phi + r \cos \phi) \sec \theta \end{bmatrix}, \quad (7)$$

where ϕ is a roll angle, θ is a pitch angle, and ψ is a yaw angle and $\sec \theta = 1 / \cos \theta$.

3. SDRE control problem

The optimal control method is well described in [2, 5, 7, 8, 24]. Interested scientists and readers can follow the state-dependent Riccati equation (SDRE) approach in the context of the nonlinear regulator problem with quadratic objective function [11, 13, 14, 20].

The finite-time control problem consists of finding optimal control law that minimizes following objective function defined for final control time t_f [32]

$$J(\mathbf{u}) = \frac{1}{2} \mathbf{x}^T(t_f) \mathbf{S} \mathbf{x}(t_f) + \frac{1}{2} \int_0^{t_f} \left(\mathbf{x}^T \mathbf{Q}(\mathbf{x}) \mathbf{x} + \mathbf{u}^T \mathbf{R}(\mathbf{x}) \mathbf{u} \right) dt, \quad (8)$$

subject to nonlinear dynamics for affine systems

$$\dot{\mathbf{x}} = \mathbf{F}(\mathbf{x}) + \mathbf{B}(\mathbf{x}) \mathbf{u}. \quad (9)$$

Nonlinear dynamics (9) can be written using the state-dependent coefficient (SDC) form [17, 33]

$$\dot{\mathbf{x}} = \mathbf{A}(\mathbf{x}) \mathbf{x} + \mathbf{B}(\mathbf{x}) \mathbf{u}. \quad (10)$$

where $\mathbf{S}(\mathbf{x})$ and $\mathbf{Q}(\mathbf{x})$ are symmetric, positive semi-definite weighting matrices for states, $\mathbf{R}(\mathbf{x})$ is the symmetric, positive definite weighting matrix for control inputs. Equation (9) includes $\mathbf{F}(\mathbf{x})$ vector, which is piecewise continuous in time and smooth respect to their arguments, which satisfy the Lipschitz condition.

Considering (10), if the pair $\{\mathbf{A}(\mathbf{x}), \mathbf{B}(\mathbf{x})\}$ is a stabilizable parameterization of the system, then to check controllability of the affine system, this pair in linear sense should be controllable. In other, checking the controllability of that pair does not need the state or control input information [13]. It can be simply checked by the matrix

$$\mathbf{M}(\mathbf{x}) = [\mathbf{B}(\mathbf{x}) \quad \mathbf{A}(\mathbf{x})\mathbf{B}(\mathbf{x}) \quad \dots \quad \mathbf{A}^{n-1}(\mathbf{x})\mathbf{B}(\mathbf{x})] \quad (11)$$

often called controllability matrix. Then the system (9) or (10) is controllable if the controllability matrix (11) has full rank.

Employing the Hamiltonian theory

$$\mathbf{H} = \frac{1}{2} \left(\mathbf{x}^T \mathbf{Q}(\mathbf{x}) \mathbf{x} + \mathbf{u}^T \mathbf{R}(\mathbf{x}) \mathbf{u} \right) + \mathbf{p}^T (\mathbf{A}(\mathbf{x}) \mathbf{x} + \mathbf{B}(\mathbf{x}) \mathbf{u}) \quad (12)$$

and considering the necessary optimality condition $\frac{\partial \mathbf{H}}{\partial \mathbf{u}} = \mathbf{0}$ with $\mathbf{p} = \mathbf{K}(\mathbf{x}) \mathbf{x}$, results in a control law as

$$\mathbf{u} = -\mathbf{R}(\mathbf{x})^{-1} \mathbf{B}(\mathbf{x})^T \mathbf{K}(\mathbf{x}) \mathbf{x}. \quad (13)$$

The control law (13) includes state-dependent feedback compensator $\mathbf{K}(\mathbf{x})$ which is a solution of SDRE.

Considering optimality conditions [2, 7, 20]:

$$\dot{\mathbf{p}} = -\frac{\partial H}{\partial \mathbf{x}} \quad \text{and} \quad \dot{\mathbf{x}} = -\frac{\partial H}{\partial \mathbf{p}} \quad (14)$$

the nonlinear system is described by state-space equation

$$\dot{\mathbf{x}} = \mathbf{A}(\mathbf{x})\mathbf{x} - \mathbf{B}(\mathbf{x})\mathbf{R}(\mathbf{x})^{-1}\mathbf{B}(\mathbf{x})^T\mathbf{p} \quad (15)$$

and following adjoint differential equation

$$\begin{aligned} \dot{\mathbf{p}} = & -\left(\frac{\partial(\mathbf{A}(\mathbf{x})\mathbf{x})}{\partial \mathbf{x}}\right)^T \mathbf{p} - \left(\frac{\partial \mathbf{B}(\mathbf{x})}{\partial \mathbf{x}} \mathbf{u}\right)^T \mathbf{p} - \mathbf{Q}(\mathbf{x})\mathbf{x} \\ & - \frac{1}{2}\mathbf{x}^T \frac{\partial \mathbf{Q}(\mathbf{x})}{\partial \mathbf{x}} \mathbf{x} - \frac{1}{2}\mathbf{u}^T \frac{\partial \mathbf{R}(\mathbf{x})}{\partial \mathbf{x}} \mathbf{u}, \end{aligned} \quad (16)$$

where

$$\frac{\partial(\mathbf{A}(\mathbf{x})\mathbf{x})}{\partial \mathbf{x}} = \mathbf{A}(\mathbf{x}) + \frac{\partial \mathbf{A}(\mathbf{x})}{\partial \mathbf{x}}\mathbf{x} \quad (17)$$

Substituting $\mathbf{p} = \mathbf{K}(\mathbf{x})\mathbf{x}$ into (16), next mathematical operations provide the following differential equation

$$\begin{aligned} & \dot{\mathbf{K}}(\mathbf{x})\mathbf{x} + \mathbf{K}(\mathbf{x})\mathbf{A}(\mathbf{x})\mathbf{x} + \mathbf{A}(\mathbf{x})^T \mathbf{K}(\mathbf{x})\mathbf{x} - \mathbf{K}(\mathbf{x})\mathbf{B}(\mathbf{x})\mathbf{R}(\mathbf{x})^{-1}\mathbf{B}(\mathbf{x})^T \mathbf{K}(\mathbf{x})\mathbf{x} \\ & + \mathbf{Q}(\mathbf{x})\mathbf{x} + \mathbf{x}^T \left(\frac{\partial \mathbf{A}(\mathbf{x})}{\partial \mathbf{x}}\right)^T \mathbf{K}(\mathbf{x})\mathbf{x} + \mathbf{u}^T \left(\frac{\partial \mathbf{B}(\mathbf{x})}{\partial \mathbf{x}}\right)^T \mathbf{K}(\mathbf{x})\mathbf{x} \\ & - \frac{1}{2}\mathbf{x}^T \frac{\partial \mathbf{Q}(\mathbf{x})}{\partial \mathbf{x}} \mathbf{x} - \frac{1}{2}\mathbf{u}^T \frac{\partial \mathbf{R}(\mathbf{x})}{\partial \mathbf{x}} \mathbf{u} = \mathbf{0}. \end{aligned} \quad (18)$$

Dimensions of derivatives of matrices $\mathbf{B}(\mathbf{x})$, $\mathbf{A}(\mathbf{x})$, $\mathbf{Q}(\mathbf{x})$ and $\mathbf{R}(\mathbf{x})$ respect to \mathbf{x} , do not have the same dimension of Eq. (18), so it must be rewritten as

$$\begin{aligned} & \dot{\mathbf{K}}(\mathbf{x}) + \mathbf{K}(\mathbf{x})\mathbf{A}(\mathbf{x}) + \mathbf{A}(\mathbf{x})^T \mathbf{K}(\mathbf{x}) - \mathbf{K}(\mathbf{x})\mathbf{B}(\mathbf{x})\mathbf{R}(\mathbf{x})^{-1}\mathbf{B}(\mathbf{x})^T \mathbf{K}(\mathbf{x}) + \mathbf{Q}(\mathbf{x}) \\ & + \left(\frac{\partial \mathbf{A}(\mathbf{x})}{\partial \mathbf{x}}\mathbf{x}\right)^T \mathbf{K}(\mathbf{x}) + \left(\frac{\partial \mathbf{B}(\mathbf{x})}{\partial \mathbf{x}}\mathbf{u}\right)^T \mathbf{K}(\mathbf{x}) \\ & + \frac{1}{2}\left(\frac{\partial \mathbf{Q}(\mathbf{x})}{\partial \mathbf{x}}\mathbf{x}\right)^T - \frac{1}{2}\left(\frac{\partial \mathbf{R}(\mathbf{x})}{\partial \mathbf{x}}\mathbf{u}\right)^T \mathbf{R}(\mathbf{x})^{-1}\mathbf{B}(\mathbf{x})^T \mathbf{K}(\mathbf{x}) = \mathbf{0} \end{aligned} \quad (19)$$

Equation (19) is a nonlinear differential optimal control equation which is the result of applying the optimality conditions and feedback control on Hamilton-Jacobi-Bellman equation (HJB). The solution to equation (19) obtains $\mathbf{K}(\mathbf{x})$ which

is the nonlinear optimal gain. In order to extract the SDRE-like form of equation (19), it is assumed that $\mathbf{K}(\mathbf{x})$ is the suboptimal solution to

$$\begin{aligned} \dot{\mathbf{K}}(\mathbf{x}) + \mathbf{K}(\mathbf{x})\mathbf{A}(\mathbf{x}) + \mathbf{A}(\mathbf{x})^T\mathbf{K}(\mathbf{x}) \\ - \mathbf{K}(\mathbf{x})\mathbf{B}(\mathbf{x})\mathbf{R}(\mathbf{x})^{-1}\mathbf{B}(\mathbf{x})^T\mathbf{K}(\mathbf{x}) + \mathbf{Q}(\mathbf{x}) = \mathbf{0} \end{aligned} \quad (20)$$

with boundary condition $\mathbf{K}(\mathbf{x}_f) = \mathbf{S}(\mathbf{x}(t_f))$, then

$$\begin{aligned} \left(\frac{\partial\mathbf{A}(\mathbf{x})}{\partial\mathbf{x}}\mathbf{x}\right)^T\mathbf{K}(\mathbf{x}) + \left(\frac{\partial\mathbf{B}(\mathbf{x})}{\partial\mathbf{x}}\mathbf{u}\right)^T\mathbf{K}(\mathbf{x}) \\ + \frac{1}{2}\left(\frac{\partial\mathbf{Q}(\mathbf{x})}{\partial\mathbf{x}}\mathbf{x}\right)^T - \frac{1}{2}\left(\frac{\partial\mathbf{R}(\mathbf{x})}{\partial\mathbf{x}}\mathbf{u}\right)^T\mathbf{R}(\mathbf{x})^{-1}\mathbf{B}(\mathbf{x})^T\mathbf{K}(\mathbf{x}) = \mathbf{0} \end{aligned} \quad (21)$$

is assumed and known as the optimality condition.

Equation (20) is in the form of differential SDRE for affine systems. Solution of the equation results in suboptimal control because it neglects (21), which is so-called “SDRE necessary condition for optimality” and it tends to zero [14].

Equation (20) known as differential SDRE or shortly SDDRE (State-Dependent Differential Riccati Equation), can be solved numerically employing different algorithms [15]. Today, very popular and classic is backward integration method to solve optimal control problem with a final boundary condition. This approach is easy to implement but unfortunately has one disadvantage, it provides two-rounded solution. The first solution generates optimal gain and the second solution gives the complete answer, called two-rounded backward and forward solutions. Another approach is based on state transition matrix technique to solve SDRE in finite-time horizon. In this approach, the starting conditions deal with introducing the state and co-state vectors obtained from Hamiltonian. Then considering the boundary condition type free, the two-level solution of the problem is reduced to one. This advantage makes the algorithm more optimal. The value of final time should be reasonable and adequate to the system dynamics. It is necessary to avoid numerical difficulties due to the inverse of the near singular transition matrix, which provides the optimal matrix gain. In general, to big values of the final time may produce computational difficulty where leads to generate a singularity problem. Finally, another commonly used technique for solving finite-time optimal control problem related to differential SDRE is Lyapunov based method. Using this approach, the feedback control gain can be computed directly. The method allows to get the positive-definite suboptimal matrix gain. It means that this procedure can work with both steady-state roots of SDRE. Then of course, the proofs of positive definiteness of the gain in both cases: for largest and smallest solution are necessary. The magic of this approach is that it works with the largest and smallest solutions, by substituting in resulting

optimal gain. However, the numerical difficulties when both solutions are used become problematic in this technique, due to computation of co-state vector. The vector sometimes may take big values and the inverse of it, may be close to singularity.

4. Stability proof

Asymptotic stability of the closed-loop system

$$\dot{\mathbf{x}} = \mathbf{A}(\mathbf{x})\mathbf{x} - \mathbf{B}(\mathbf{x})\mathbf{R}(\mathbf{x})^{-1}\mathbf{B}(\mathbf{x})^T\mathbf{K}(\mathbf{x})\mathbf{x} \quad (22)$$

implies that it is possible to control the states from the initial values to the final ones. The stability the SDDRE can be presented via Lyapunov approach. The Lyapunov candidate function is structured as

$$\mathbf{V}(\mathbf{x}) = \mathbf{x}^T\mathbf{K}(\mathbf{x})\mathbf{x}. \quad (23)$$

Taking the time derivative of Lyapunov candidate function and substituting with equations (13) and (20), results in

$$\dot{\mathbf{V}}(\mathbf{x}) = -\mathbf{x}^T \left(\mathbf{K}(\mathbf{x})\mathbf{B}(\mathbf{x})\mathbf{R}(\mathbf{x})^{-1}\mathbf{B}(\mathbf{x})^T\mathbf{K}(\mathbf{x}) + \mathbf{Q}(\mathbf{x}) \right) \mathbf{x} \quad (24)$$

which is non-negative since the matrices $\mathbf{Q}(\mathbf{x})$, $\mathbf{R}(\mathbf{x})$ and $\mathbf{K}(\mathbf{x})$ are positive-definite and $\mathbf{B}(\mathbf{x})\mathbf{R}(\mathbf{x})^{-1}\mathbf{B}(\mathbf{x})^T$ is also non-negative.

In summary, having derivative of Lyapunov function (23), the local exponentially stability, and hence the local uniform asymptotic stability of the system (22) follows [2, 7, 20]. The local stability result cannot be readily generalized to the global stability, however, such generalization can be carried out through utilizing the concept of region of attraction [14] for defined bounded set

$$\Omega = \{ \mathbf{x} \in \mathbf{R}^n, \dot{\mathbf{V}}(\mathbf{x}) \leq c, \quad t \in [t_0, t_f] \}, \quad (25)$$

where c is a positive constant.

5. Control system analysis

The nonlinear F16 aircraft model is applied to check the described finite-time SDRE control for flight stabilization when the wind or other external forces try to destabilize aircraft flight-path. Governing equations that describe aircraft aerodynamics are given by (5)-(6), but for the control purpose, state-dependent parametrization SDC is necessary. When considering the flight dynamics for

nonzero speed $u \neq 0$, parametrized F16 model (10) based on system (5) and (6) with gravity compensation, can be described in SDC form

$$\begin{bmatrix} \dot{u} \\ \dot{v} \\ \dot{w} \\ \dot{p} \\ \dot{q} \\ \dot{r} \end{bmatrix} = \begin{bmatrix} (g \sin \theta)/u & 0 & 0 & 0 & -w & v \\ (-g \sin \theta \cos \theta)/u & 0 & 0 & w & 0 & -u \\ (-g \cos \theta \cos \theta)/u & 0 & 0 & -v & u & 0 \\ 0 & 0 & 0 & 0 & c_1 p + c_2 r & 0 \\ 0 & 0 & 0 & c_3 p & 0 & c_4 p - c_3 r \\ 0 & 0 & 0 & 0 & c_5 p + c_6 r & 0 \end{bmatrix} \begin{bmatrix} u \\ v \\ w \\ p \\ q \\ r \end{bmatrix} + \begin{bmatrix} 1/m & 0 & 0 & 0 \\ 0 & 0 & 0 & 0 \\ 0 & 0 & 0 & 0 \\ 0 & c_{lp} & 0 & c_{nr} \\ c_{mq} Z_{TP} & 0 & c_{mq} & 0 \\ 0 & c_{lr} & 0 & c_{nr} \end{bmatrix} \begin{bmatrix} F_T \\ L \\ M \\ N \end{bmatrix}, \quad (26)$$

where control vector consists of thrust F_T , and rolling, pitching, yawing moments resulted from arrangements of ailerons, elevators and rudder [34].

As shown in Fig. 2, the thrust acts positively along the positive body x -axis. Positive thrust cause an increase in acceleration along the body x -axis. For the other control surfaces a positive deflection gives a decrease in the body rates. A positive aileron deflection δ_a gives a decrease in the roll rates, this requires that the right aileron deflect downward and the left aileron deflect upward. A positive elevator deflection δ_e results in a decrease in pitch rate, thus elevator is deflected downwards. Positive deflection of the rudder δ_r decreases the yaw rate, and can be described as a deflection to right. The maximum control values and units are listed in Table 1.

Table 1: Minimum and maximum control values

Control	Value [quantity]
F_T	~ 150 [kN]
δ_e	$-25 \div 25$ [deg]
δ_a	$-21.5 \div 21.5$ [deg]
δ_r	$-30 \div 30$ [deg]

Considering defined real controls, arranged by aircraft pilot, neglecting leading edge flaps effect and assuming quasi-linear relationship between aircraft moments and above described controls (the linearization is possible at the trim point), the state-space system of equation (26) can be recalculated for new controls

presented in Table 1

$$\begin{bmatrix} \dot{u} \\ \dot{v} \\ \dot{w} \\ \dot{p} \\ \dot{q} \\ \dot{r} \end{bmatrix} = \begin{bmatrix} (g \sin \theta)/u & 0 & 0 & 0 & -w & v \\ (-g \sin \theta \cos \theta)/u & 0 & 0 & w & 0 & -u \\ (-g \cos \theta \cos \theta)/u & 0 & 0 & -v & u & 0 \\ 0 & 0 & 0 & 0 & c_1 p + c_2 r & 0 \\ 0 & 0 & 0 & c_3 p & 0 & c_4 p - c_3 r \\ 0 & 0 & 0 & 0 & c_5 p + c_6 r & 0 \end{bmatrix} \begin{bmatrix} u \\ v \\ w \\ p \\ q \\ r \end{bmatrix} + \begin{bmatrix} 1/m & 0 & 0 & 0 & 0 & 0 \\ 0 & 0 & 0 & 0 & 0 & 0 \\ 0 & 0 & 0 & 0 & 0 & 0 \\ 0 & 0 & c_{lp}c_{l1} + c_{np}c_{n1} & c_{lp}c_{l2} + c_{np}c_{n2} & 0 & 0 \\ c_{mq}Z_{TP} & c_{mq}c_{m1} & 0 & 0 & 0 & 0 \\ 0 & 0 & c_{lr}c_{l1} + c_{nr}c_{n1} & c_{lr}c_{l2} + c_{nr}c_{n2} & 0 & 0 \end{bmatrix} \begin{bmatrix} F_T \\ \delta_e \\ \delta_a \\ \delta_r \end{bmatrix}, \quad (27)$$

where coefficients c_{l1} , c_{l2} , c_{m1} , c_{n1} , c_{n2} are derived from the density of air flowing in and Mach number, the geometry of the wing structure including its span, the mean aerodynamic chord and wing area.

The F16 aircraft properties [1,23] used with certain assumptions and indicated values to be able to perform further calculations in the chapter due to the model (5)–(6) and (26)–(27) are presented in Table 2.

Table 2: Mass, inertia and other properties of F16

Parameter	Value [quantity]
m	9295 [kg]
I_{xx}	12874.8 [$\text{kg} \times \text{m}^2$]
I_{yy}	75673.6 [$\text{kg} \times \text{m}^2$]
I_{zz}	85552.1 [$\text{kg} \times \text{m}^2$]
I_{xz}	1331.4 [$\text{kg} \times \text{m}^2$]
Z_{TP}	0.3 [m]
c_{l1}	0.8
c_{l2}	0.2
c_{m1}	1.2
c_{n1}	0.2
c_{n2}	0.8

Employing described aircraft model, the SDRE control method is applied to control the flight stabilization problem, considering two values of finite control times: $t_f = 3$ s and $t_f = 5$ s. As mentioned in introduction, the time is very

important, because the aircraft should rapidly answer for pilot commands. The path of flight must be sometimes rapidly stabilized when unexpected external forces try to change the aircraft position and orientation during flying action.

Considering above, the problem consists of finding F16 aircraft state dynamics and SDRE controls. In association with the aircraft dynamics (26), the quadratic cost functional weighting matrices in (8) are chosen as

$$\mathbf{S} = 5 \cdot 10^3 \begin{bmatrix} 1 & 0.15 & 0 & 0 & 0 & 0 \\ 0.15 & 1 & 0 & 0 & 0 & 0 \\ 0 & 0 & 1 & 0 & 0 & 0 \\ 0 & 0 & 0 & 1 & 0 & 0 \\ 0 & 0 & 0 & 0 & 1 & 0 \\ 0 & 0 & 0 & 0 & 0 & 1 \end{bmatrix}, \quad \mathbf{Q} = 5 \cdot 10^3 \mathbf{I}_{6 \times 6}.$$

and $\mathbf{R} = 2 \cdot 10^{-4} \mathbf{I}_{4 \times 4}$ with initial speeds $u = 300$ km/h, $v = -20$ km/h, $w = 20$ km/h and angle $\theta = 5^\circ$, in other hand, presenting it in vector form $\mathbf{x}_0 = [300 \cdot 0.28 \quad -25 \cdot 0.28 \quad 20 \cdot 0.28 \quad 0 \quad 5 \cdot \pi/180 \quad 0]^T$, where 0.28 is a constant that allows to recalculate the speed in km/h to m/s and $\pi/180$ allows to recalculate degs to rads. The control should stabilize the aircraft in finite time t_f and uphold linear speed u on prescribed level, it means that the final state conditions should be as follows, for instance $\mathbf{x}_f = [500 \cdot 0.28 \quad 0 \quad 0 \quad 0 \quad 0 \quad 0]^T$. Considering the final state, control law (13) takes the form

$$\mathbf{u} = -\mathbf{R}(\mathbf{x})^{-1} \mathbf{B}(\mathbf{x})^T \mathbf{K}(\mathbf{x})(\mathbf{x} - \mathbf{x}_f). \quad (28)$$

Simulations are done to show the performance of the control designed in Section 3. The aircraft state dynamics, controls and flight trajectory from initial state to the final state are shown below.

Firstly, simulations are performed for the final time $t_f = 3$ s.

Next simulations are performed for the final time $t_f = 5$ s.

Figures 3–12 show closed-loop response of the flight controller and F16 aircraft system. Simulations are performed for two assumptions of the final control time t_f : 3 and 5 seconds. Simulation time for both cases is two times longer than control time t_f , because it is interesting how the system works after t_f when transversality condition holds.

When look at Figs. 3 and 8, it is worth to observe that for $t_f = 3$ s, the aircraft is faster stabilized by feedback control and increase altitude z only within 3.1 meters and distance x approximately 202 meters. For the $t_f = 5$ s, the aircraft is also stabilized well, but the aircraft change the altitude to 4.6 meters at the distance x equal to 585 meters. Hence the aircraft can be successively controlled within assumed finite control times.

When consider controls, firstly thrust and aircraft moments shown at Figs. 4a–4b and Figs. 9a–9b, further elevators, ailerons and rudder functions of deflection,

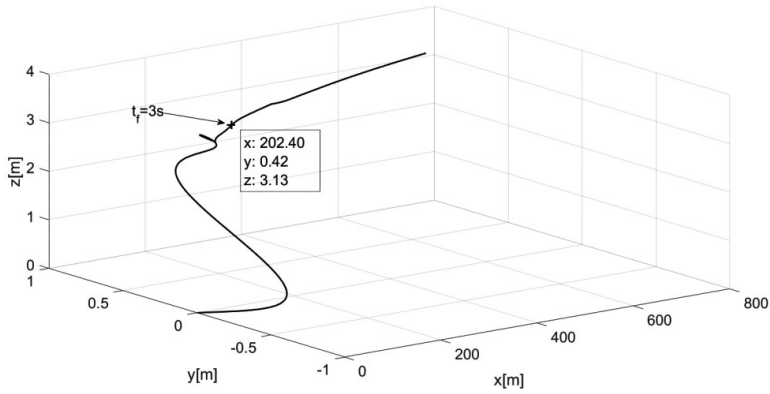
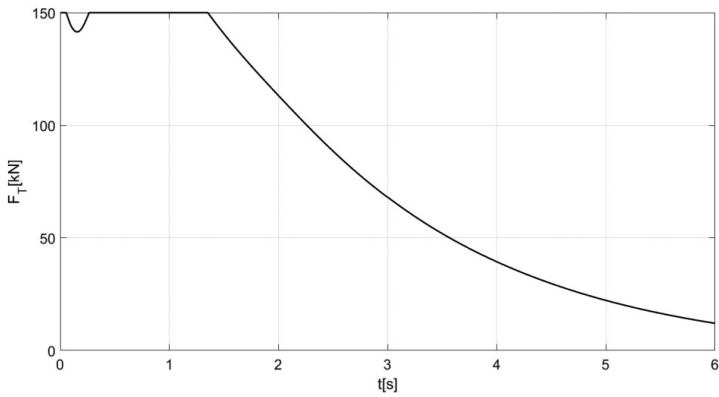
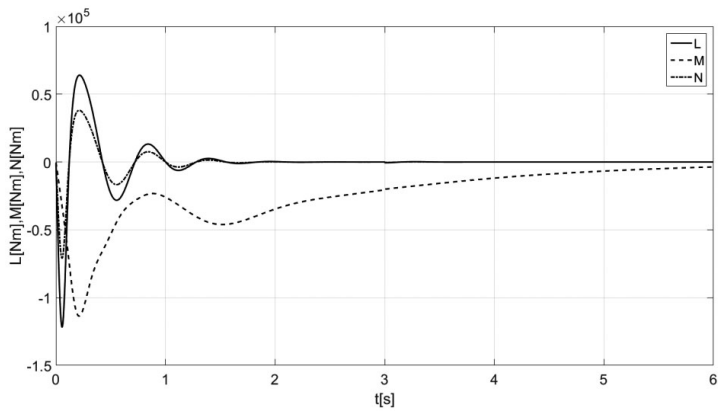

Figure 3: Aircraft flight trajectory



(a) Thrust force control



(b) Rolling, pitching and yawing moments

Figure 4

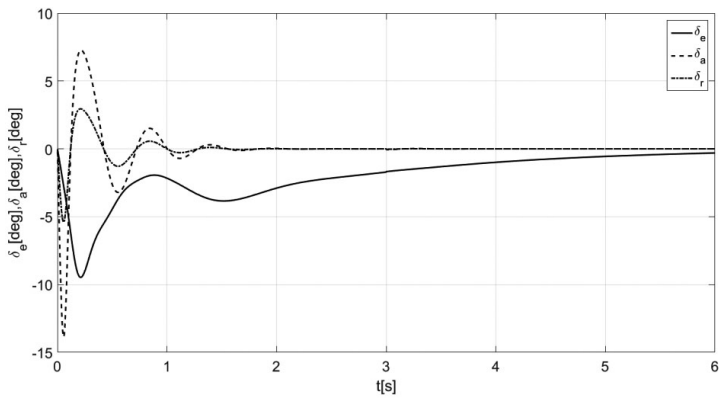

Figure 5: Elevators, ailerons and rudder deflection

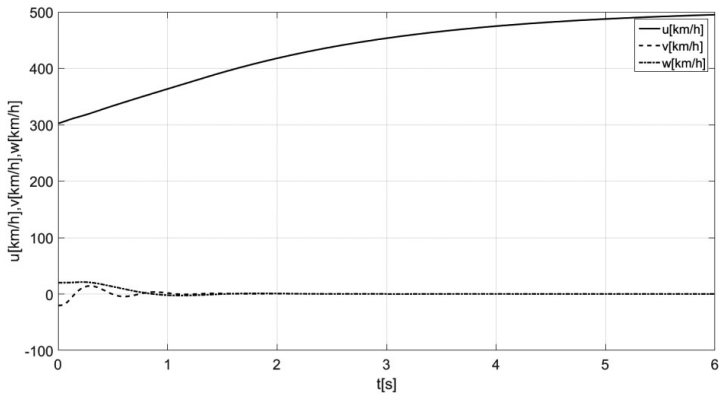

Figure 6: Aircraft speeds

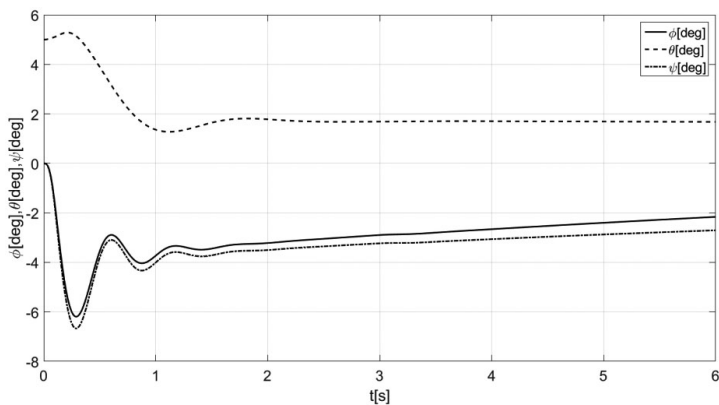

Figure 7: Roll, pitch and yaw angles

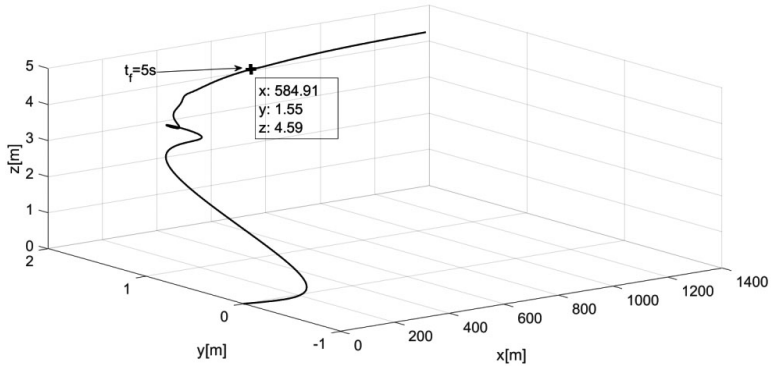
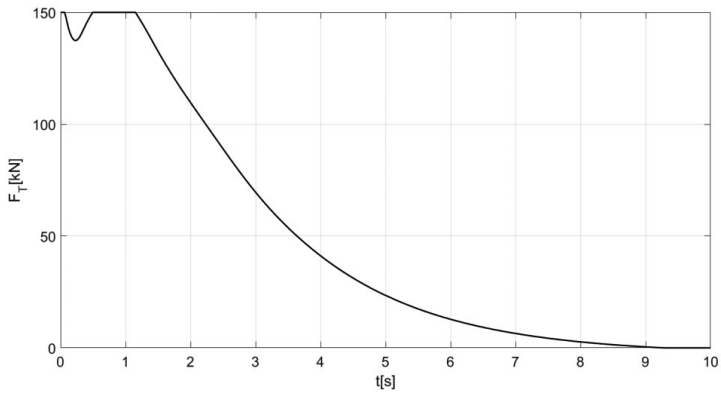
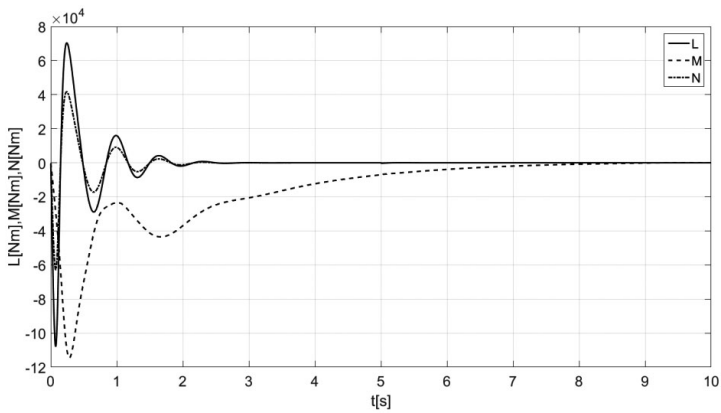

Figure 8: Aircraft flight trajectory



(a) Thrust force control



(b) Rolling, pitching and yawing moments

Figure 9

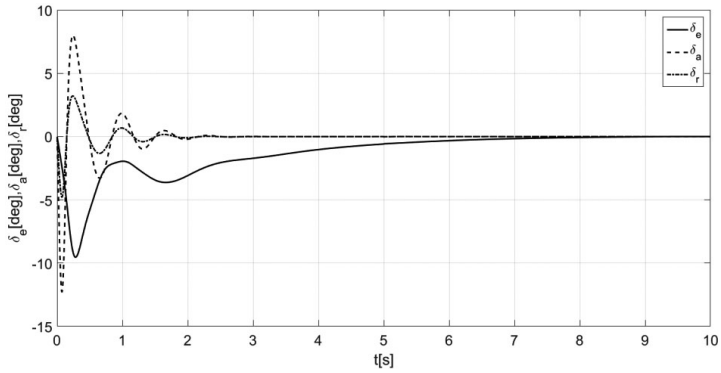

Figure 10: Elevators, ailerons and rudder deflection

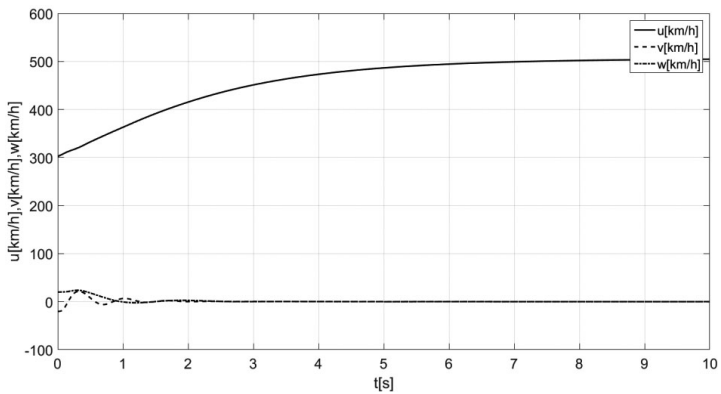

Figure 11: Aircraft speeds

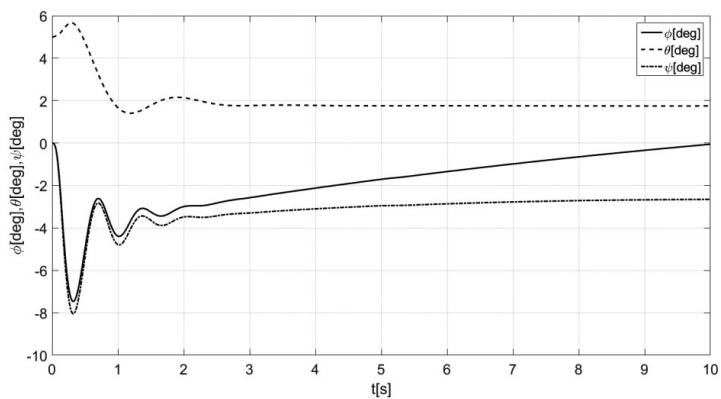

Figure 12: Roll, pitch and yaw angles

the maximum thrust is kept longer for shorted control time $t_f = 3$ s. Moments and deflection functions are similar for both cases, except yawing moments and rudder deflections. The thrust is kept longer for $t_f = 3$ s because the aircraft must faster stabilize and straighten flight trajectory.

Analysis of the aircraft speeds, presented at Figs. 6 and 11, proof that speed in the flight direction is increased to 500 km/h with simultaneously zeroing other speeds for both cases. The situation is consistent to assumed starting and final state conditions. Additionally, the solution of kinematics is presented at Figs. 7 and 12. There is shown how evaluates the aircraft space orientation.

6. Conclusions

The finite time control problem for flight stabilization in flight control system in multirole F16 aircraft is formulated and solved. The nonlinear, state-dependent parametrized model of the aircraft is proposed. The optimal control technique with nonlinear feedback compensator for computation of the control input that minimizes energy delivered to the aircraft system and energy lost, performing stabilization task is analyzed. The effectiveness of presented technique is demonstrated on a numerical example where optimal aircraft controls are found for different final times. Presented results proof, that proposed SDRE technique can be successively applied to the F16 flight control aircraft systems.

References

- [1] W. AHMED, Z. LI, H. MAQSOOD, and B. ANWAR: System modeling and controller design for lateral and longitudinal motion of F-16. *Automation, Control and Intelligent Systems*, **7**(1), (2019), 39–45. DOI: [10.11648/j.acis.20190701.15](https://doi.org/10.11648/j.acis.20190701.15).
- [2] H.T. BANKS, B.M. LEWIS, and H.T. TRAN: Nonlinear feedback controllers and compensators: a state-dependent Riccati equation approach. *Computational Optimization and Applications*, **37**(2), (2007), 177–218. DOI: [10.1007/s10589-007-9015-2](https://doi.org/10.1007/s10589-007-9015-2).
- [3] J.C.A. BARATA and M.S. HUSSEIN: *The Moore-Penrose Pseudoinverse. A Tutorial Review of the Theory*. John Hopkins University Press, 2013.
- [4] A. BRACCI, M. INNOCENTI, and L. POLLINI: Estimation of the region of attraction for state-dependent Riccati equation controllers. *Journal of Guidance, Control and Dynamics*, **29**(6), (2006), 1427–1430. DOI: [10.2514/1.22122](https://doi.org/10.2514/1.22122).

- [5] T. CIMEN and S.P. BANKS: Global optimal feedback control for general nonlinear systems with non-quadratic performance criteria. *System and Control Letters*, **53**(5), (2004), 327–346. DOI: [10.1016/j.sysconle.2004.05.008](https://doi.org/10.1016/j.sysconle.2004.05.008).
- [6] T. CIMEN and S.P. BANKS: Nonlinear optimal tracking control with application to super-tankers for autopilot design. *Automatica*, **40**(11), (2004), 1845–1863. DOI: [10.1016/j.automatica.2004.05.015](https://doi.org/10.1016/j.automatica.2004.05.015).
- [7] T. ÇIMEN: Systematic and effective design of nonlinear feedback controllers via the state-dependent Riccati equation (SDRE) method. *Annual Reviews in Control*, **34**(1), (2010), 32–51. DOI: [10.1016/j.arcontrol.2010.03.001](https://doi.org/10.1016/j.arcontrol.2010.03.001).
- [8] J.R. CLOUTIER, C.N. D’SOUZA, and C.P. MRACEK: Nonlinear regulation and nonlinear H_∞ control via the state-dependent Riccati equation technique: Part 1, Theory; Part 2, Examples. In: *Proceedings of the First International Conference on Nonlinear Problems in Aviation and Aerospace*, Daytona Beach, FL, (1996), 117–141.
- [9] R. CZYBA and L. STAJER: Dynamic contraction method approach to digital longitudinal aircraft flight controller design. *Archives of Control Sciences*, **29**(1), (2019), 97–109. DOI: [10.24425/acs.2019.127525](https://doi.org/10.24425/acs.2019.127525).
- [10] E.B. ERDEM and A.G. ALLEYNE: Globally stabilizing second-order nonlinear systems by SDRE control. In: *Proceedings of the American Control Conference*, San Diego, CA, USA, (1999). DOI: [10.1109/ACC.1999.786502](https://doi.org/10.1109/ACC.1999.786502).
- [11] E.B. ERDEM and A.G. ALLEYNE: Design of a class of nonlinear controllers via state dependent Riccati equations. *IEEE Transactions on Control Systems Technology*, **12**(1), (2004), 133–137. DOI: [10.1109/TCST.2003.819588](https://doi.org/10.1109/TCST.2003.819588).
- [12] J. GENG, Y. SHENG, and X. LIU: Finite-time sliding mode attitude control for a reentry vehicle with blended aerodynamic surfaces and a reaction control system. *Chinese Journal of Aeronautics*, **27**(4), (2014), 964–976. DOI: [10.1016/j.cja.2014.03.013](https://doi.org/10.1016/j.cja.2014.03.013).
- [13] K.D. HAMMETT, C.D. HALL, and D.B. RIDGELY: Controllability issues in nonlinear state-dependent Riccati equation control. *Journal of Guidance, Control and Dynamics*, **21**(54), (1998), 767–773. DOI: [10.2514/2.4304](https://doi.org/10.2514/2.4304).
- [14] A. HEYDARI and S.N. BALAKRISHNAN: Closed-form solution to finite-horizon suboptimal control of nonlinear systems. *International Journal of Robust Nonlinear Control*, **25**(15), (2015), 2687–2704. DOI: [10.1002/rnc.3222](https://doi.org/10.1002/rnc.3222).
- [15] M.H. KORAYEM and S.R. NEKOO: Finite-time state-dependent Riccati equation for time-varying nonaffine systems: Rigid and flexible joint manip-

- ulator control. *ISA Transactions*, **54**, (2015), 125–144. DOI: [10.1016/j.isatra.2014.06.006](https://doi.org/10.1016/j.isatra.2014.06.006).
- [16] Q.M. LAM, M. XIN, and J.R. CLOUTIER: SDRE control stability criteria and convergence issues: where are we today addressing practitioners' concerns?, In: *AIAA papers*, (2012), 2012–2475. DOI: [10.2514/6.2012-2475](https://doi.org/10.2514/6.2012-2475).
- [17] Y.W. LIANG and L.G. LIN: On factorization of the nonlinear drift term for SDRE approach. In: *Proceedings of the 18th World congress IFAC.*, **44**(1), (2011), 9607–9612. DOI: [10.3182/20110828-6-IT-1002.00808](https://doi.org/10.3182/20110828-6-IT-1002.00808).
- [18] K. LU and Y. XIA: Finite-time fault-tolerant control for rigid spacecraft with actuator saturations. *IET Control Theory and Applications*, **7**(11), (2013), 1529–1539. DOI: [10.1049/iet-cta.2012.1031](https://doi.org/10.1049/iet-cta.2012.1031).
- [19] D.G. MITCHELL, R.H. HOH, B.L. APONSO, and D.H. KLYDE: The measurement and prediction of pilot-in-the-loop oscillations. In: *AIAA Papers*, (1994), 94–3670. DOI: [10.2514/6.1994-3670](https://doi.org/10.2514/6.1994-3670).
- [20] C.P. MRACEK and J.R. CLOUTIER: Control designs for the nonlinear benchmark problem via the state-dependent Riccati equation method. *International Journal of Robust Nonlinear Control*, **8**(4–5), (1998), 401–433. DOI: [10.1002/\(SICI\)1099-1239\(19980415/30\)8:4/5](https://doi.org/10.1002/(SICI)1099-1239(19980415/30)8:4/5).
- [21] J.D. PEARSON: Approximation methods in optimal control. *Journal of Electronics and Control*, **13**, (1962), 453–469. DOI: [10.1080/00207216208937454](https://doi.org/10.1080/00207216208937454).
- [22] E. PROMTUN and S. SESHAGIRI: Sliding mode control of pitch-rate of an F-16 aircraft. *IFAC Proceedings Volumes (IFAC Papers-OnLine)*, **41**(2), (2008), 1099–1104. DOI: [10.3182/20080706-5-KR-1001.00190](https://doi.org/10.3182/20080706-5-KR-1001.00190).
- [23] W.C. REIGELSPERGER and S.S. BANDA: Nonlinear simulation of a modified F-16 with full-envelope control laws. *Control Engineering Practice*, **6**(3), (1998) 309–320. DOI: [10.1016/S0967-0661\(98\)00024-0](https://doi.org/10.1016/S0967-0661(98)00024-0).
- [24] J.S. SHAMMA and J.R. CLOUTIER: Existence of SDRE stabilizing feedback. *IEEE Transactions on Automatic Control*, **48**(3), (2003), 513–517. DOI: [10.1109/TAC.2002.808473](https://doi.org/10.1109/TAC.2002.808473).
- [25] M. SIWCZYŃSKI and K. HAWRON: Optimum tasks and solutions for energy transmission from the source to the receiver. *Bulletin of the Polish Academy of Sciences. Technical Sciences*, **66**(5), (2018), 655–663. DOI: [10.24425/124281](https://doi.org/10.24425/124281).
- [26] M. SZNAIER, J. CLOUTIER, R. HULL, D. JACQUES, and C. MRACEK: Receding horizon control Lyapunov function approach to suboptimal regulation of

- nonlinear systems. *Journal of Guidance, Control and Dynamics*, **23**(3), (2000), 399–405. DOI: [10.2514/2.4571](https://doi.org/10.2514/2.4571).
- [27] I. TANYER, E. TATLICIOGLU, and E. ZERGEROGLU: Output tracking control of an aircraft subject to additive state dependent disturbance: an optimal control approach. *Archives of Control Sciences*, **31**(2), (2021), 267–286. DOI: [10.24425/acs.2021.137418](https://doi.org/10.24425/acs.2021.137418).
- [28] K.K. VARANASI and S. NAYFEH: The dynamics of lead-screw drivers: low order modeling and experiments. *Transactions of ASME*, **126**, (2004), 388–396. DOI: [10.1115/1.1771690](https://doi.org/10.1115/1.1771690).
- [29] N. WAHID, M.F.A. RAHMAT, and K. JUSOFF: Comparative assesment using LQR and fuzzy logic controller for a pitch control system. *European Journal of Scientific Research*, **42**(2), (2010), 184–194.
- [30] N. WANG, J. YU AND W. LIN: Positioning control of linear actuator with nonlinear friction and input saturation using output feedback control. *Complexity*, **21**(S2), (2016), 191–200. DOI: [10.1002/cplx.21797](https://doi.org/10.1002/cplx.21797).
- [31] F. WANG, Q. ZONG, and B. TIAN: Adaptive backstepping finite time attitude control of reentry RLV with input constraint. *Mathematical Problems in Engineering*, **5**, (2014), 1–19. DOI: [10.1155/2014/801747](https://doi.org/10.1155/2014/801747).
- [32] A. WERNLI and G. COOK: Suboptimal control for the nonlinear quadratic regulator problem. *Automatica*, **11**(1), (1975), 75–84. DOI: [10.1016/0005-1098\(75\)90010-2](https://doi.org/10.1016/0005-1098(75)90010-2).
- [33] Y.W. LIANG and L.G. LIN: Analysis of SDC matrices for successfully implementing the SDRE scheme. *Automatica*, **49**(10), (2013), 3120–3124. DOI: [10.1016/j.automatica.2013.07.026](https://doi.org/10.1016/j.automatica.2013.07.026).
- [34] W. DURHAM: *Aircraft Flight Dynamics and Control*. First Edition, John Wiley & Sons Ltd., 2013.
- [35] M.V. COOK: *Flight Dynamics Principles*. Second Edition, Elsevier Aerospace Engineering Series, 2007.
- [36] Flight Control Design – Best Practices, RTO TECHNICAL REPORT 29, RTO/NATO 2000 [Online]. Available: [https://www.sto.nato.int>RTO- TR-029](https://www.sto.nato.int>RTO-TR-029) [Accessed: 6. July 2021]
- [37] The F-16 combines interoperability and advanced technologies into a proven design [Online]. Available: <https://www.lockheedmartin.com/en-us/products/f-16.html> [Accessed: 6. July 2021].